

SuperLine
Product / Manual Catalog

Dentium
For Dentists By Dentists

Specifications are subject to change without any notice.
Some products listed in this catalog are not available in the market due to pending approval.

HEAD OFFICE
501 Gyeonggi R&DB Center, 105 Gwanggyo-ro, Yeongtong-gu, Suwon-si, Gyeonggi-do, Korea [16229]
T +82-31-888-5431 F +82-31-888-5430
E-mail biz_mail@dentium.com / www.dentium.com

SPMC-1805 [Rev.0]

SuperLine Product / Manual Catalog

SPMC-1805[Rev.0]

SuperLine
Product / Manual Catalog
2018

Dentium
For Dentists By Dentists

Contents

SuperLine	SuperLine Characteristics	04
	SuperLine Fixture Specifications	05
	SuperLine Fixture	06
Surgical Components	Cover Screw	07
	GBR Healing Abutment	07
	Healing Abutment	08
	IOS Healing Abutment	10
Prosthetic Procedure 1	Dual / Combi Abutment - Abutment Level Impression	11
	Combi Abutment	12
	Dual Abutment	13
	Abutment Level Impression Components	15
	Restorative Kit	16
Prosthetic Procedure 2	Dual / Custom / Milling / Angled / Direct-Casting / Metal-Casting / Temporary (Plastic & Ti) Abutment - Fixture Level Impression	17
	Fixture Level Impression Components	19
	Custom Abutment	20
	Milling Abutment	21
	Angled Abutment	23
	Direct-Casting Abutment	25
	Metal-Casting Abutment	25
	Ti-Temporary Abutment	26
	Plastic Temporary Abutment	26
	Prosthetic Procedure 3	Screw Abutment - Abutment Level Impression
Screw Abutment		28
Angled Screw Abutment		29
Screw Abutment Impression Components		30
Prosthetic Procedure 4	Overdenture Procedure - Positioner / Mini Ball / Magnetic Attachment	33
	Positioner	34
	Mini Ball Attachment	36
	Magnetic Attachment	37

Instruments	Surgical Kit (Full)	39
	Surgical Kit (Standard)	40
	Surgical Kit (Short Implant)	41
	Drill Stopper Kit	42
	Surgical Instruments	43
	DASK	51
	Sinus Bur Kit	52
	Sinus Kit	53
	DASK / Sinus Bur Kit / TN Brush	54
	Osteotome Kit	55
	Trephine Kit	56
	Instrument	57
	Membrane Pins & Screws	58
	Prosthetic Kit	59
	Planning Kit	60
	Prosthetic and Laboratory Instrument	61
	Help Kit	62
Polymer Guide Kit	63	
Sinus Kit	64	
Ridge Expander Kit	65	
Implant Guide Kit	66	
Digital Full Kit	67	
Digital Simple Kit	68	
	Surgical Manual	70
	Prosthesis Manual	79





S.L.A. Surface

S.L.A. (Sandblasting with Large grits and Acid etching)

- Higher bone-to-implant contact
- Faster bone formation on the surface

reference: Kim H., et. al. "The Biocompatibility of SLA-treated Titanium Implants" Biomed. Mater. 2008; 3(2):025011

In vivo test

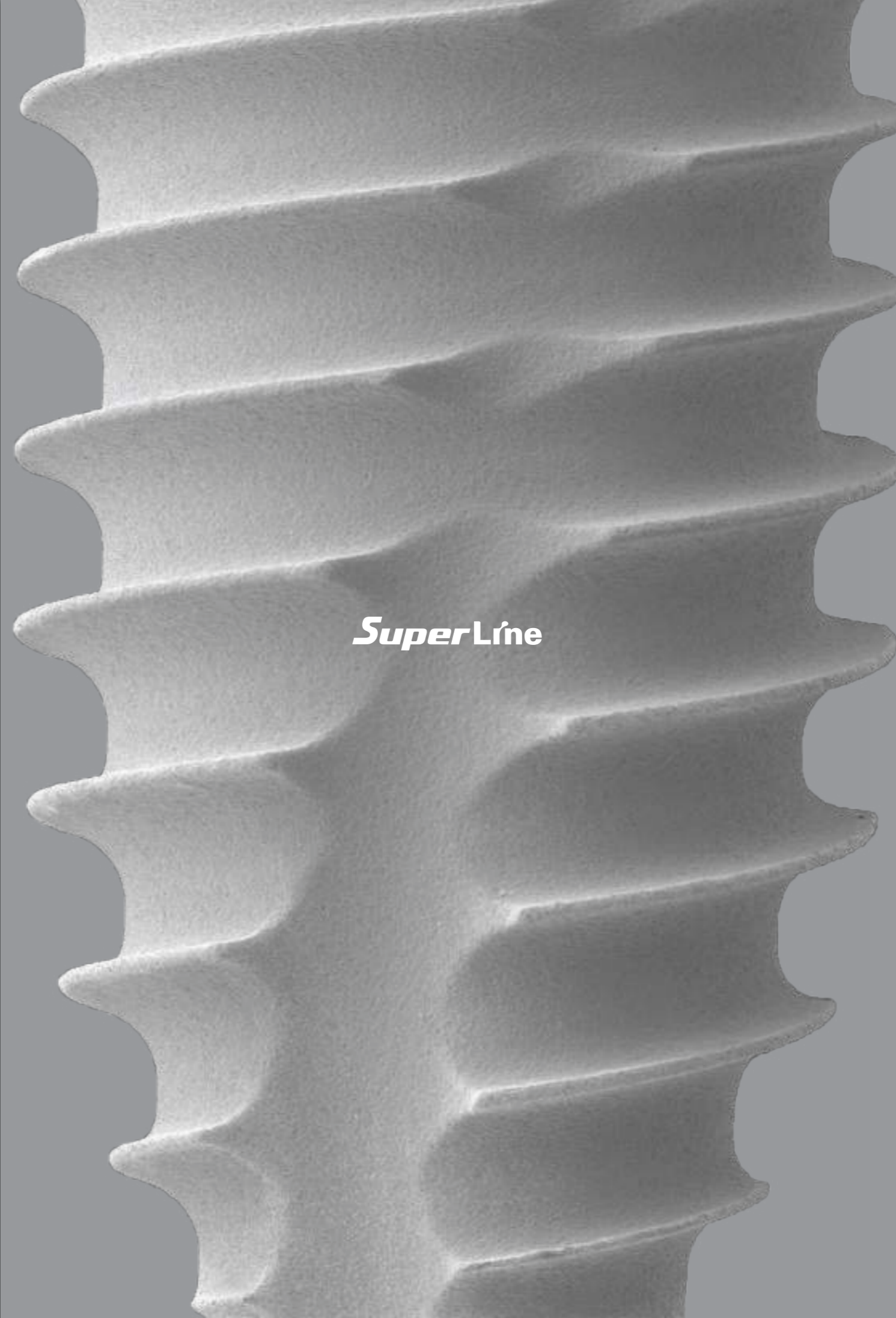

SuperLine

SuperLine Characteristics

Joint stability & Improved strength for zirconia crown

· Abutment material: Grade 4 ➔ Alloy

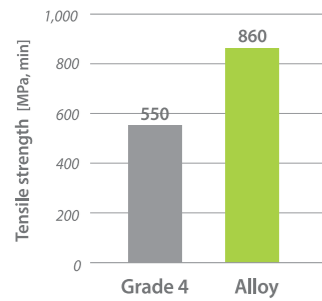

· Long hex design: Improved recognition

Improved soft tissue management

- Concave abutment design
- Non-coating

Improved wall thickness

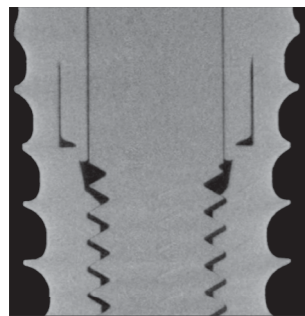

Double thread & Tapered design



Double threaded tapered body design may provide good success rate in immediate loading cases.

reference: Kim et. al., "A Prospective, 1-year observational study of double-threaded tapered body dental implants with immediate loading" J Prosthet Dent 2015;114:46-51

Increased thread height and sharper

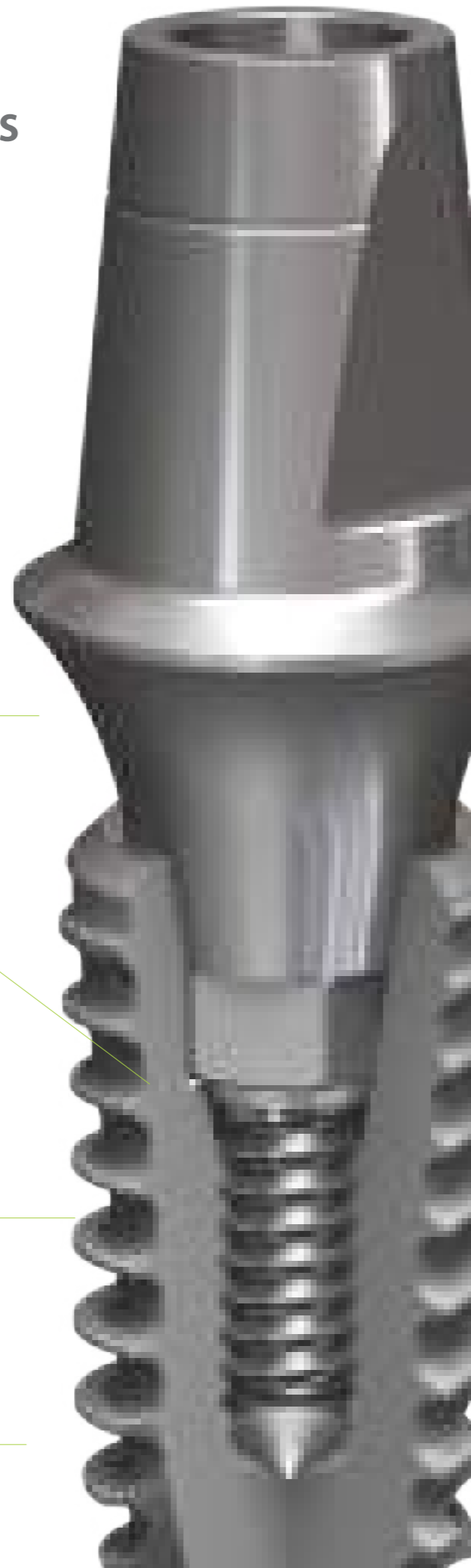

SuperLine Fixture Specifications

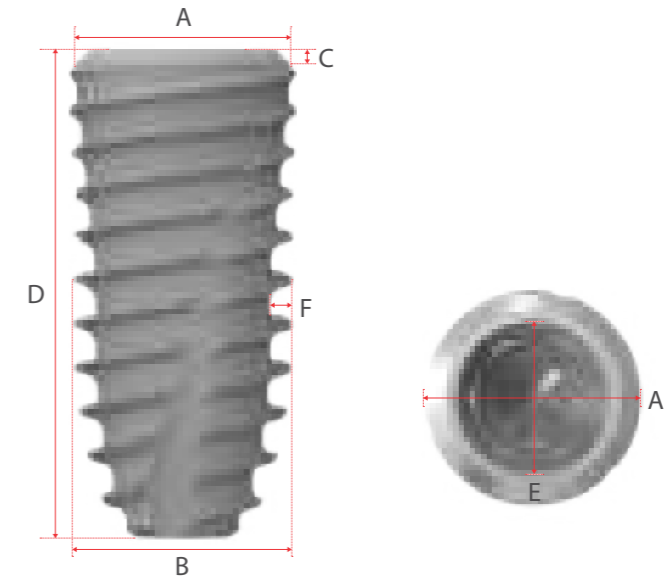

Fixture (Mount Free)								
A	Platform Diameter(Ø)	3.6	4.0	4.4	4.9	6.0	7.0	
B	Body Diameter(Ø)	3.6	4.0	4.5	5.0	5.0	5.8	
C	Bevel Height (mm)	L: 7	1.5	1.5	1.5	1.5	1.5	1.5
		L: 8, 10, 12, 14	0	0.1	0.3	0.4	0.7	1.0
D	Total Length(mm)	7, 8, 10, 12, 14						
E	Abutment Interface(Ø)	3.33	3.33	3.33	3.33	3.33	3.33	
F	Thread Depth(mm)	0.38	0.40	0.45	0.50	0.55	0.60	
Cap Color								
		Yellow	Green	Blue	Red	Orange	Violet	
Selection Guideline		Anterior	Anterior	Premolar	Molar	Molar	Molar	

SuperLine Fixture

· Cover screw is not included in the package

Platform	Body	L	Art. No.
Ø 3.6	Ø 3.6	7	FX 36 07 SW
		8	FX 36 08 SW
		10	FX 36 10 SW
		12	FX 36 12 SW
		14	FX 36 14 SW
Ø 4.0	Ø 4.0	7	FX 40 07 SW
		8	FX 40 08 SW
		10	FX 40 10 SW
		12	FX 40 12 SW
		14	FX 40 14 SW
Ø 4.4	Ø 4.5	7	FX 45 07 SW
		8	FX 45 08 SW
		10	FX 45 10 SW
		12	FX 45 12 SW
		14	FX 45 14 SW
Ø 4.9	Ø 5.0	7	FX 50 07 SW
		8	FX 50 08 SW
		10	FX 50 10 SW
		12	FX 50 12 SW
		14	FX 50 14 SW
Ø 6.0	Ø 5.0	7	FX 60 07 SW
		8	FX 60 08 SW
		10	FX 60 10 SW
		12	FX 60 12 SW
		Ø 7.0	Ø 5.8
8	FX 70 08 SW		
10	FX 70 10 SW		
12	FX 70 12 SW		

Unit: mm, Scale 1.5 : 1

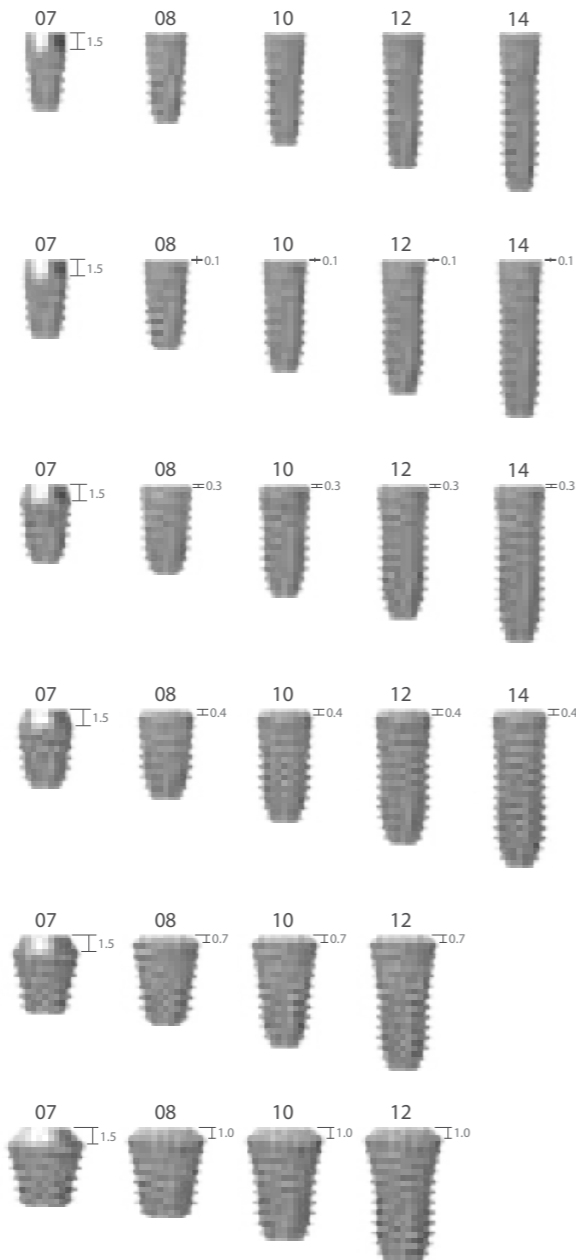

Cover Screw

Unit: mm, Scale 1.5 : 1

- Single use only
- Must sterilize prior to use

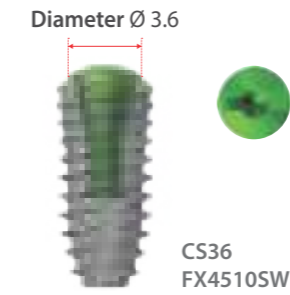

Color	Diameter	Art. No.
Green	Ø 3.6	CS 36



※ Hex driver: Use no more than 5N-cm of torque when screwing a cover screw to a fixture.
If hex is worn, slot on the head of the product can be used to rotate it.

GBR Healing Abutment

Unit: mm, Scale 1.5 : 1

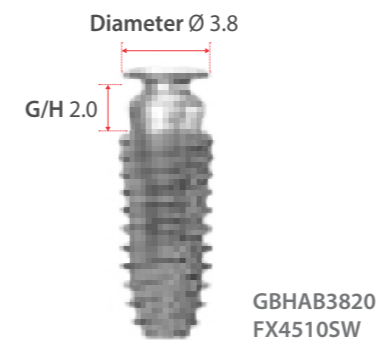

Diameter	G/H	Art. No.
Ø 3.3	3.5	GBHAB 33 35
Ø 3.8	0.5	GBHAB 38 05
Ø 3.8	2.0	GBHAB 38 20



※ Note: To prevent damage to the Implant driver or fixture, do not over torque during fixture insertion.

※ Hex driver: Use no more than 10N-cm of torque when screwing a healing abutment to a fixture.
If hex is worn, slot on the head of the product can be used to rotate it.

Healing Abutment

Unit: mm, Scale 1.5 : 1

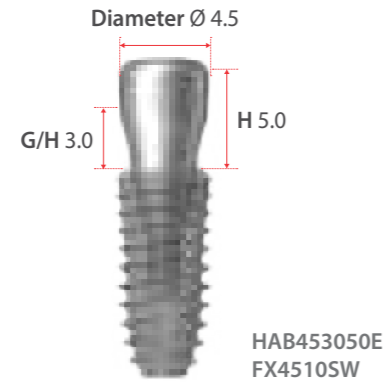

Diameter	G/H	H	Art. No.
Ø 4.0	2.0	2.0	HAB 40 20 20 E
	2.0	3.5	HAB 40 20 35 E
	3.0	5.0	HAB 40 30 50 E
	4.0	7.0	HAB 40 40 70 E
Ø 4.5	2.0	2.0	HAB 45 20 20 E
	2.0	3.5	HAB 45 20 35 E
	3.0	5.0	HAB 45 30 50 E
	4.0	7.0	HAB 45 40 70 E
Ø 5.5	2.0	2.0	HAB 55 20 20 E
	2.0	3.5	HAB 55 20 35 E
	3.0	5.0	HAB 55 30 50 E
	4.0	7.0	HAB 55 40 70 E
Ø 6.5	2.0	2.0	HAB 65 20 20 E
	2.0	3.5	HAB 65 20 35 E
	3.0	5.0	HAB 65 30 50 E
	4.0	7.0	HAB 65 40 70 E

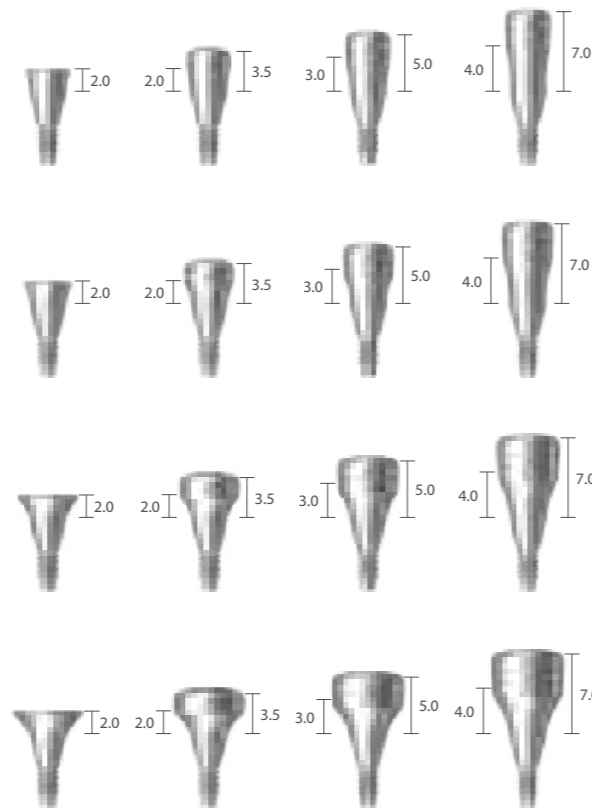

※ Hex driver: Use no more than 10N-cm of torque when screwing a healing abutment to a fixture.
If hex is worn, slot on the head of the product can be used to rotate it.

Healing Abutment

Unit: mm, Scale 1.5 : 1

Diameter	G/H	H	Art. No.
Ø 7.5	2.0	3.5	HAB 75 20 35 E
	3.0	5.0	HAB 75 30 50 E

Diameter	G/H	H	Art. No.
Ø 8.5	2.0	3.5	HAB 85 20 35 E
	3.0	5.0	HAB 85 30 50 E

Diameter	G/H	H	Art. No.
Ø 9.5	2.0	3.5	HAB 95 20 35 E
	3.0	5.0	HAB 95 30 50 E

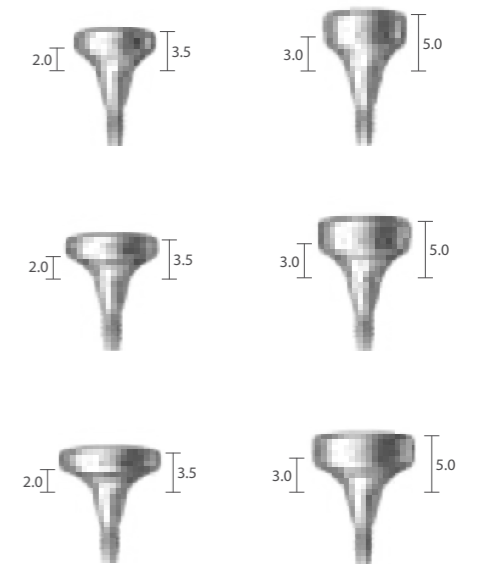

※ Hex driver: Use no more than 10N-cm of torque when screwing a healing abutment to a fixture.
If hex is worn, slot on the head of the product can be used to rotate it.

IOS Healing Abutment

Unit: mm, Scale 1.5 : 1

Diameter	G/H	Type	Art. No.
Ø 4.0	6.0	Hex	IHAB 40 06 H
	6.0	Non-hex	IHAB 40 06 N
	8.0	Hex	IHAB 40 08 H
	8.0	Non-hex	IHAB 40 08 N
	10.0	Hex	IHAB 40 10 H
	10.0	Non-hex	IHAB 40 10 N

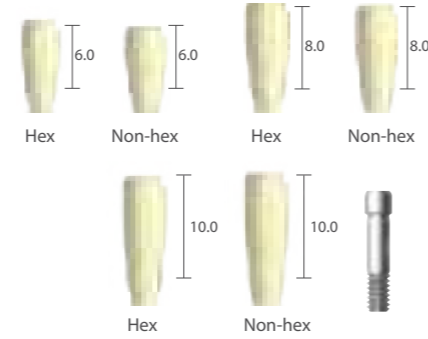

Diameter	G/H	Type	Art. No.
Ø 5.0	6.0	Hex	IHAB 50 06 H
	6.0	Non-hex	IHAB 50 06 N
	8.0	Hex	IHAB 50 08 H
	8.0	Non-hex	IHAB 50 08 N
	10.0	Hex	IHAB 50 10 H
	10.0	Non-hex	IHAB 50 10 N

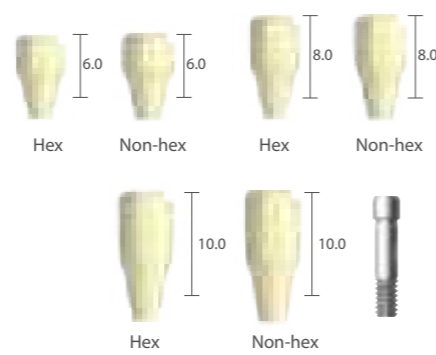

Diameter	G/H	Type	Art. No.
Ø 6.0	6.0	Hex	IHAB 60 06 H
	6.0	Non-hex	IHAB 60 06 N
	8.0	Hex	IHAB 60 08 H
	8.0	Non-hex	IHAB 60 08 N
	10.0	Hex	IHAB 60 10 H
	10.0	Non-hex	IHAB 60 10 N

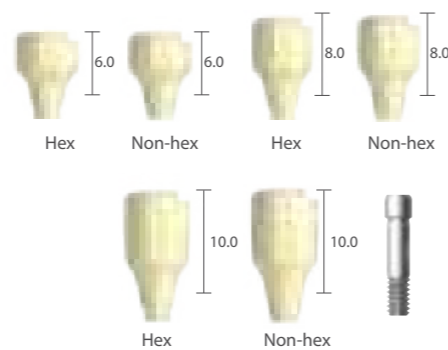

Prosthetic Procedure 1

Impression Technique and Restoration Selection

Dual / Combi Abutment

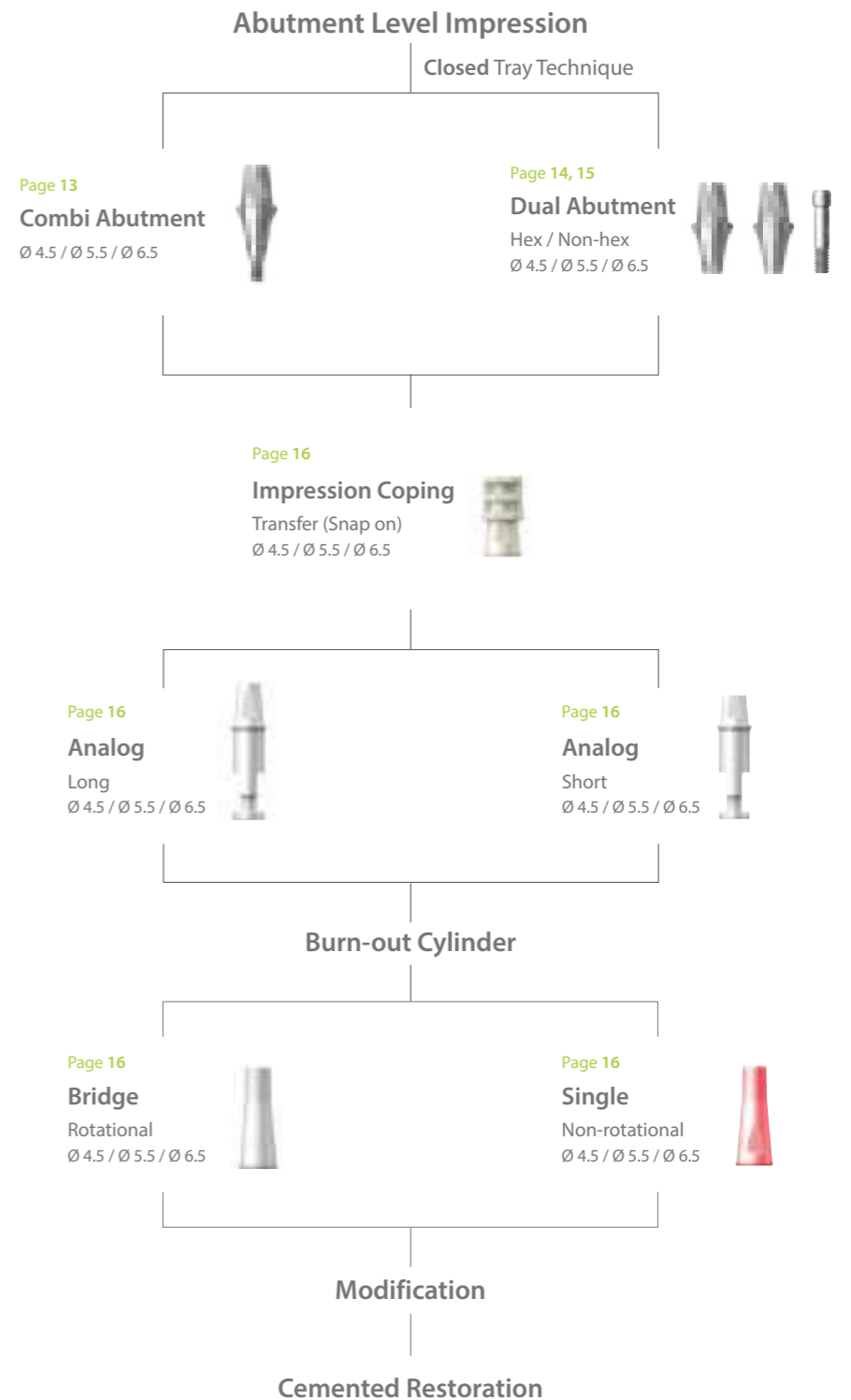

※ Hex driver: Use no more than 10N-cm of torque when screwing a healing abutment to a fixture.
If hex is worn, slot on the head of the product can be used to rotate it.

Combi Abutment

Unit: mm, Scale 1 : 1

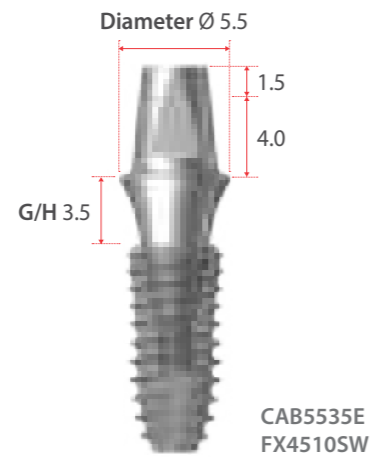

CAB5535E
FX4510SW

Diameter	G/H	Type	Art. No.	Type	Art. No.
Ø 4.5	1.0	Short	CAB 45 10 SE	Long	CAB 45 10 E
	1.5		CAB 45 15 SE		CAB 45 15 E
	2.5		CAB 45 25 SE		CAB 45 25 E
	3.5		CAB 45 35 SE		CAB 45 35 E
	4.5		CAB 45 45 SE		CAB 45 45 E
	5.5		CAB 45 55 SE		CAB 45 55 E

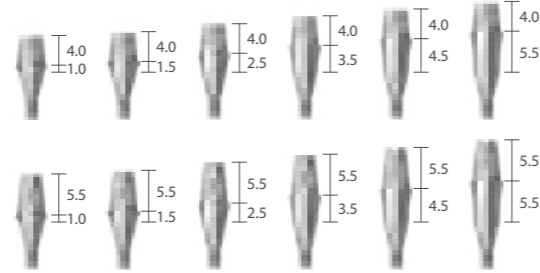

Ø 5.5	1.5	Short	CAB 55 15 SE	Long	CAB 55 15 E
	2.5		CAB 55 25 SE		CAB 55 25 E
	3.5		CAB 55 35 SE		CAB 55 35 E
	4.5		CAB 55 45 SE		CAB 55 45 E
	5.5		CAB 55 55 SE		CAB 55 55 E

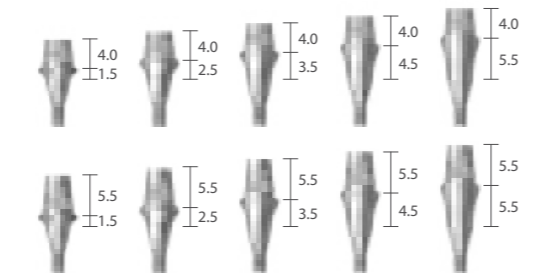

Ø 6.5	1.5	Short	CAB 65 15 SE	Long	CAB 65 15 E
	2.5		CAB 65 25 SE		CAB 65 25 E
	3.5		CAB 65 35 SE		CAB 65 35 E
	4.5		CAB 65 45 SE		CAB 65 45 E
	5.5		CAB 65 55 SE		CAB 65 55 E

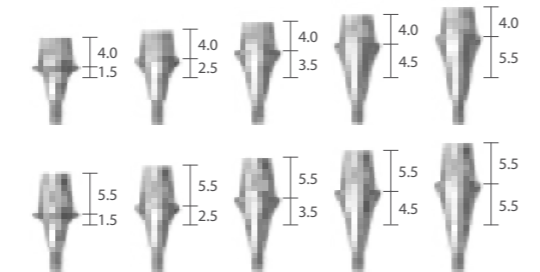

※ Note: It is recommended to keep the torque level at 25~30 N·cm to tighten the combi abutment with fixture.

Dual Abutment_Hex

Unit: mm, Scale 1.5 : 1

· Abutment screw is included

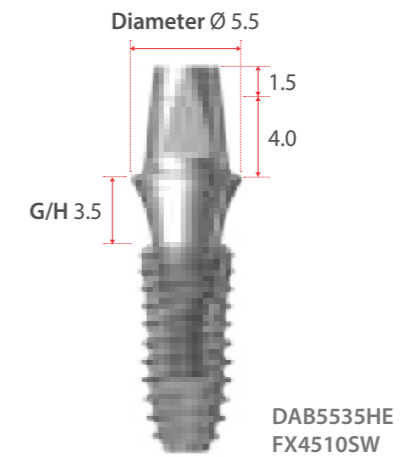

DAB5535HE
FX4510SW

Diameter	G/H	Art. No.
Ø 4.5	1.0	DAB 45 10 HE
	1.5	DAB 45 15 HE
	2.5	DAB 45 25 HE
	3.5	DAB 45 35 HE
	4.5	DAB 45 45 HE
	5.5	DAB 45 55 HE

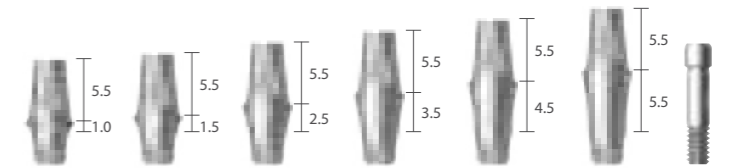

Ø 5.5	1.5	DAB 55 15 HE
	2.5	DAB 55 25 HE
	3.5	DAB 55 35 HE
	4.5	DAB 55 45 HE
	5.5	DAB 55 55 HE

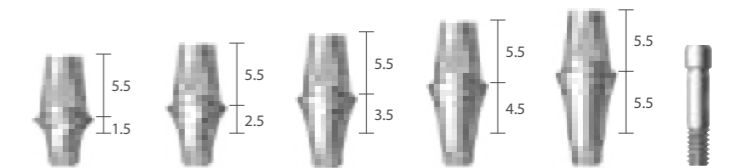

Ø 6.5	1.5	DAB 65 15 HE
	2.5	DAB 65 25 HE
	3.5	DAB 65 35 HE
	4.5	DAB 65 45 HE
	5.5	DAB 65 55 HE

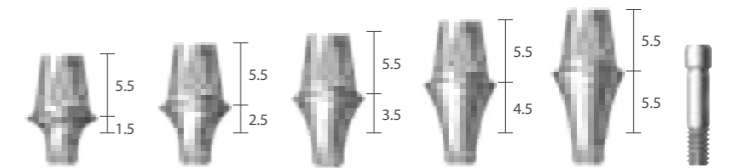

※ Note: It is recommended to keep the torque level at 25~30 N·cm to tighten the dual abutment with fixture.

Dual Abutment_Non-hex

Unit: mm, Scale 1.5 : 1

· Abutment screw is included

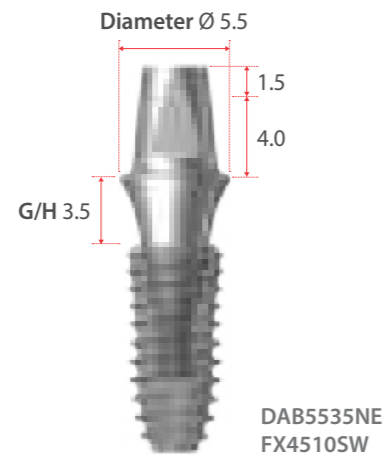

Diameter	G/H	Art. No.
Ø 4.5	1.0	DAB 45 10 NE
	1.5	DAB 45 15 NE
	2.5	DAB 45 25 NE
	3.5	DAB 45 35 NE
	4.5	DAB 45 45 NE
	5.5	DAB 45 55 NE
Ø 5.5	1.5	DAB 55 15 NE
	2.5	DAB 55 25 NE
	3.5	DAB 55 35 NE
	4.5	DAB 55 45 NE
	5.5	DAB 55 55 NE
Ø 6.5	1.5	DAB 65 15 NE
	2.5	DAB 65 25 NE
	3.5	DAB 65 35 NE
	4.5	DAB 65 45 NE
	5.5	DAB 65 55 NE

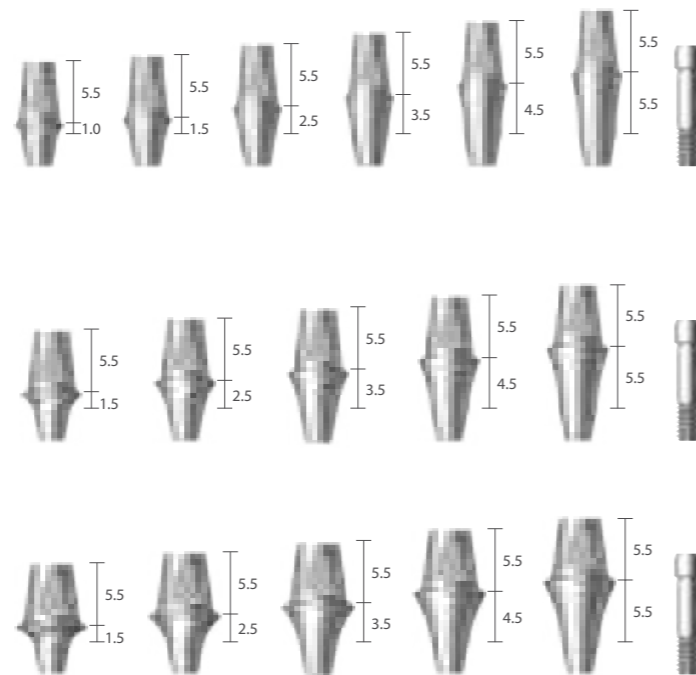

※ Note: It is recommended to keep the torque level at 25~30 N·cm to tighten the dual abutment with fixture.

Abutment Level Impression Components

Unit: mm, Scale 1 : 1

Comfort Cap | Snap on

Type	Diameter	Art. No.
Short	Ø 4.5	CCC 45 CS
	Ø 5.5	CCC 55 CS
	Ø 6.5	CCC 65 CS
Long	Ø 4.5	CCC 45 C
	Ø 5.5	CCC 55 C
	Ø 6.5	CCC 65 C



Impression Coping

Diameter	Art. No.
Ø 4.5	CIC 45 L
Ø 5.5	CIC 55 L
Ø 6.5	CIC 65 L



Lab Analog

Type	Diameter	Art. No.
Short	Ø 4.5	CAN 45 SL
	Ø 5.5	CAN 55 SL
	Ø 6.5	CAN 65 SL
Long	Ø 4.5	CAN 45 LL
	Ø 5.5	CAN 55 LL
	Ø 6.5	CAN 65 LL

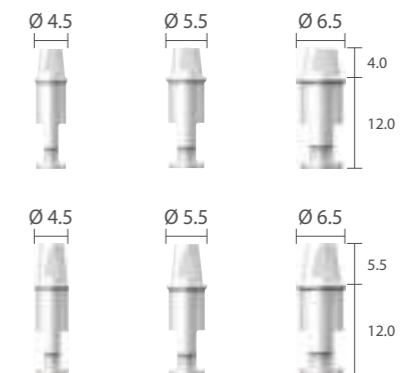

Burn-out Cylinder

Type	Diameter	Art. No.
Single	Ø 4.5	CBC 45 SL
	Ø 5.5	CBC 55 SL
	Ø 6.5	CBC 65 SL
Bridge	Ø 4.5	CBC 45 BL
	Ø 5.5	CBC 55 BL
	Ø 6.5	CBC 65 BL



Restorative Kit



Combi & Dual Abutment

Art. No	Lab. Components				
	Comfort Cap	Impression Coping	Analog	Burn-out Cylinder	
XSDAB 45 S XSDAB 45	CCC 45 CS CCC 45 C	CIC 45 L	CAN 45 SL CAN 45 LL	CBC 45 SL	CBC 45 BL
XSDAB 55 S XSDAB 55	CCC 55 CS CCC 55 C	CIC 55 L	CAN 55 SL CAN 55 LL	CBC 55 SL	CBC 55 BL
XSDAB 65 S XSDAB 65	CCC 65 CS CCC 65 C	CIC 65 L	CAN 65 SL CAN 65 LL	CBC 65 SL	CBC 65 BL

Prosthetic Procedure 2

Impression Technique and Restoration Selection

Dual / Custom / Milling / Angled / Direct-Casting / Metal-Casting /
Ti-Temporary / Plastic Temporary Abutment

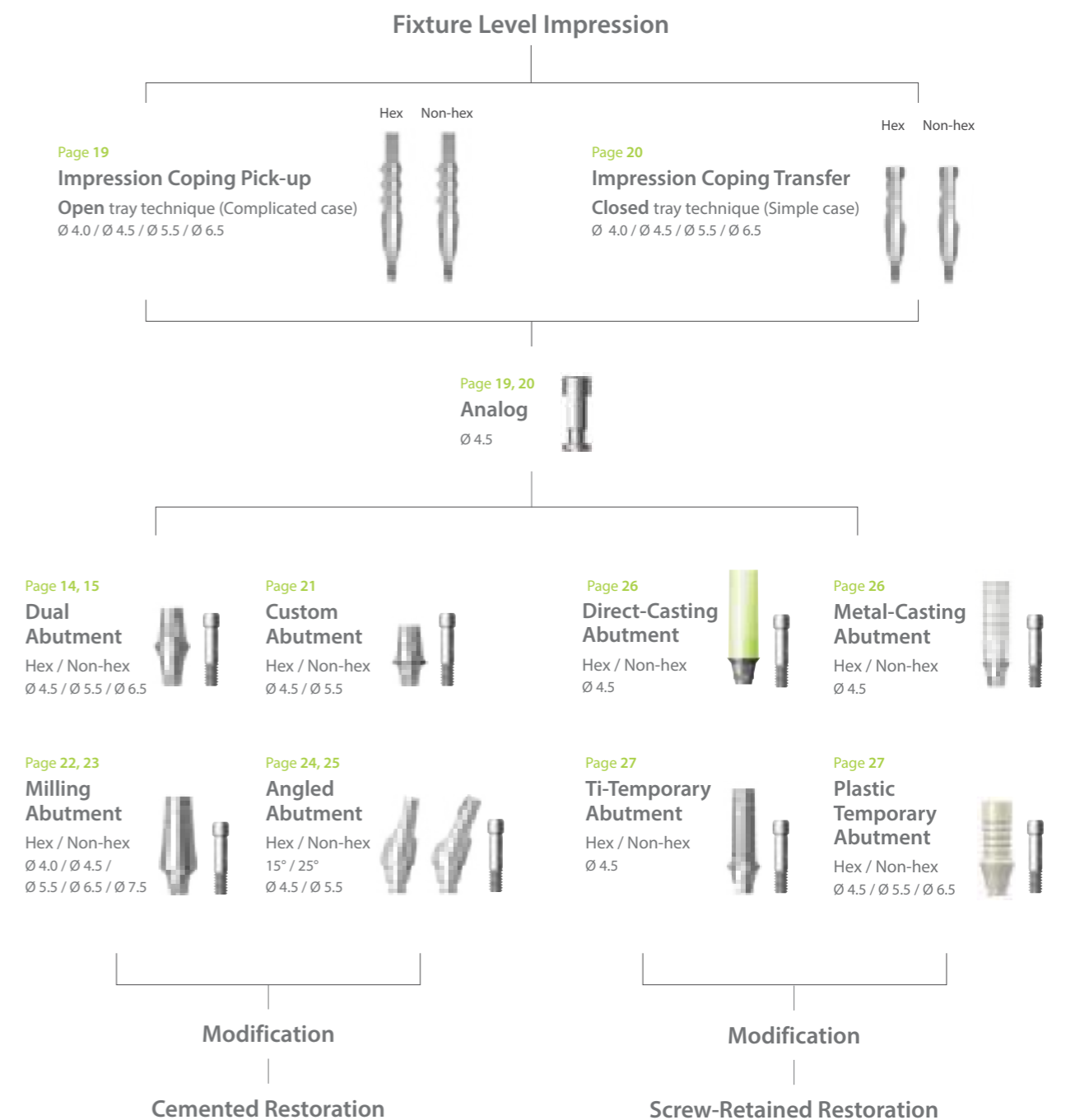

Fixture Level Impression Components

Unit: mm, Scale 1 : 1

· Impression coping screw is included with Impression coping.

Impression Coping Pick-up

Diameter	Size	Type	Art. No.
Ø 4.0	Short	Hex	DPU 40 11 HE
	Short	Non-hex	DPU 40 11 NE
	Long	Hex	DPU 40 15 HE
	Long	Non-hex	DPU 40 15 NE

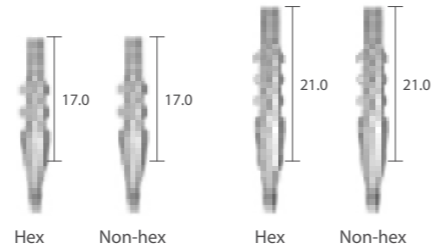

Ø 4.5	Short	Hex	DPU 45 11 HE
	Short	Non-hex	DPU 45 11 NE
	Long	Hex	DPU 45 15 HE
	Long	Non-hex	DPU 45 15 NE

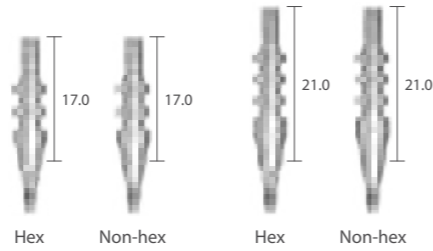

Ø 5.5	Short	Hex	DPU 55 11 HE
	Short	Non-hex	DPU 55 11 NE
	Long	Hex	DPU 55 15 HE
	Long	Non-hex	DPU 55 15 NE

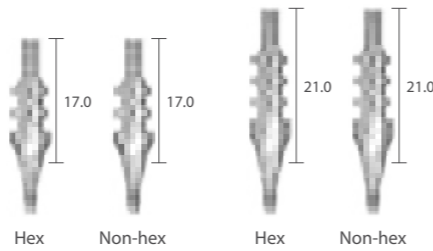

Ø 6.5	Short	Hex	DPU 65 11 HE
	Short	Non-hex	DPU 65 11 NE
	Long	Hex	DPU 65 15 HE
	Long	Non-hex	DPU 65 15 NE

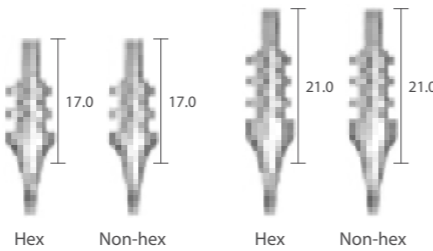

Impression Coping Transfer Screw

Size	L	Art. No.
Short	23.0	DPS 11 E
Long	27.0	DPS 15 E

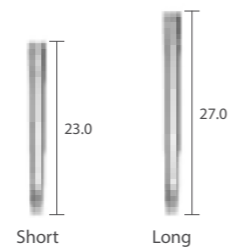

Analog

Diameter	L	Art. No.
Ø 4.5	12.0	DANSE

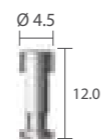

Fixture Level Impression Components

Unit: mm, Scale 1 : 1

· Impression coping screw is included with Impression coping.

Impression Coping Transfer

Diameter	Size	Type	Art. No.
Ø 4.0	Short	Hex	DTF 40 11 HE
	Short	Non-hex	DTF 40 11 NE
	Long	Hex	DTF 40 15 HE
	Long	Non-hex	DTF 40 15 NE

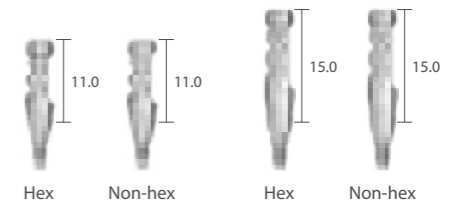

Ø 4.5	Short	Hex	DTF 45 11 HE
	Short	Non-hex	DTF 45 11 NE
	Long	Hex	DTF 45 15 HE
	Long	Non-hex	DTF 45 15 NE

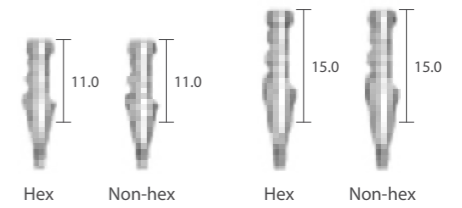

Ø 5.5	Short	Hex	DTF 55 11 HE
	Short	Non-hex	DTF 55 11 NE
	Long	Hex	DTF 55 15 HE
	Long	Non-hex	DTF 55 15 NE

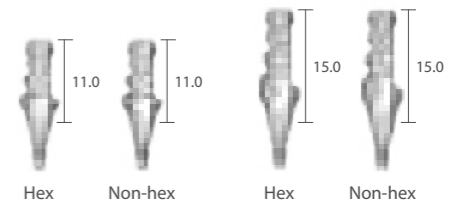

Ø 6.5	Short	Hex	DTF 65 11 HE
	Short	Non-hex	DTF 65 11 NE
	Long	Hex	DTF 65 15 HE
	Long	Non-hex	DTF 65 15 NE

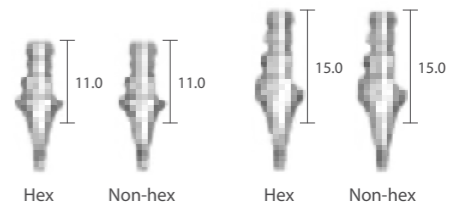

Impression Coping Transfer Screw

Size	L	Art. No.
Short	17.0	DTS 11 E
Long	21.0	DTS 15 E

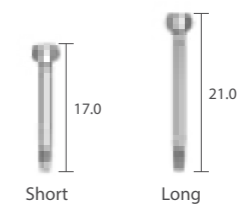

Analog

Diameter	L	Art. No.
Ø 4.5	12.0	DANSE

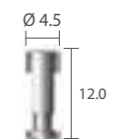

Custom Abutment

Unit: mm, Scale 1.5 : 1

· Abutment screw is included.

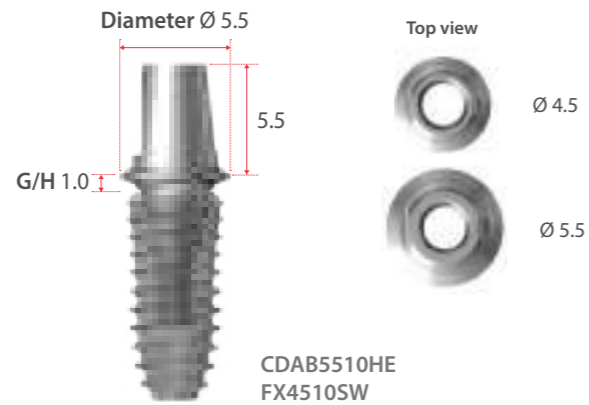

CDAB5510HE
FX4510SW

Diameter	G/H	Type	Art. No.
Ø 4.5	0.5	Hex	CDAB 45 05 HE
	0.5	Non-hex	CDAB 45 05 NE
	1.5	Hex	CDAB 45 15 HE
	1.5	Non-hex	CDAB 45 15 NE
Ø 5.5	1.0	Hex	CDAB 55 10 HE
	1.0	Non-hex	CDAB 55 10 NE
	2.0	Hex	CDAB 55 20 HE
	2.0	Non-hex	CDAB 55 20 NE

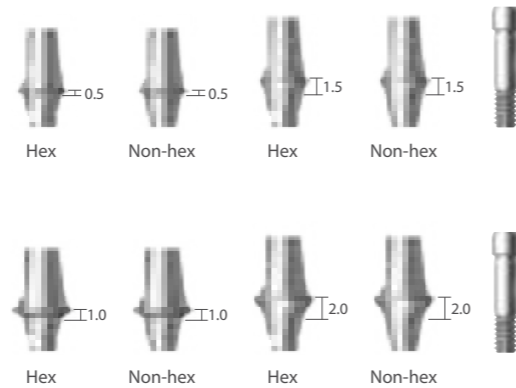

※ Note: It is recommended to keep the torque level at 25~30 N·cm to tighten the custom abutment with fixture.

Milling Abutment

Unit: mm, Scale 1.5 : 1

· Abutment screw is included.

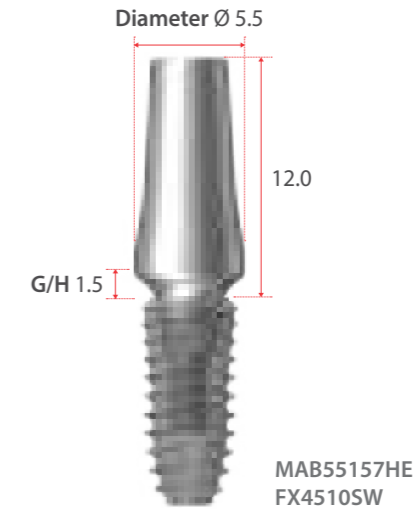

MAB55157HE
FX4510SW

Diameter	G/H	Type	Art. No.
Ø 4.0	1.0	Hex	MAB 40 105 HE
	1.0	Non-hex	MAB 40 105 NE



Diameter	G/H	Type	Art. No.
Ø 4.5	1.5	Hex	MAB 45 156 HE
	1.5	Non-hex	MAB 45 156 NE

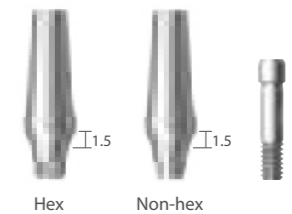

Diameter	G/H	Type	Art. No.
Ø 5.5	1.5	Hex	MAB 55 157 HE
	1.5	Non-hex	MAB 55 157 NE
	2.5	Hex	MAB 55 257 HE
	2.5	Non-hex	MAB 55 257 NE

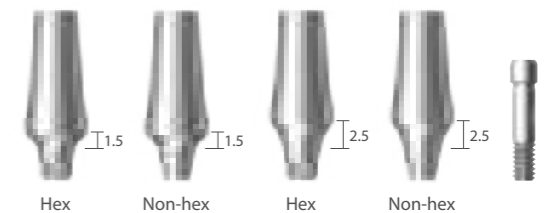

※ Note: It is recommended to keep the torque level at 25~30 N·cm to tighten the milling abutment with fixture.

Milling Abutment

Unit: mm, Scale 1.5 : 1

· Abutment screw is included.

Diameter	G/H	Type	Art. No.
Ø 6.5	1.5	Hex	MAB 65 158 HE
	1.5	Non-hex	MAB 65 158 NE
	2.5	Hex	MAB 65 258 HE
	2.5	Non-hex	MAB 65 258 NE
	3.5	Hex	MAB 65 358 HE
	3.5	Non-hex	MAB 65 358 NE

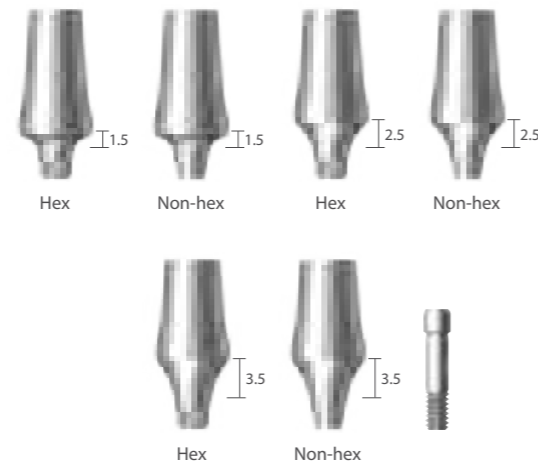

Diameter	G/H	Type	Art. No.
Ø 7.5	2.5	Hex	MAB 75 259 HE
	2.5	Non-hex	MAB 75 259 NE
	3.5	Hex	MAB 75 359 HE
	3.5	Non-hex	MAB 75 359 NE

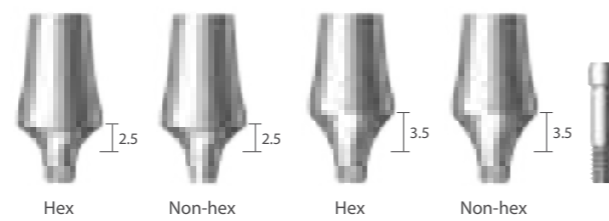

※ Note: It is recommended to keep the torque level at 25~30 N·cm to tighten the milling abutment with fixture.

Angled Abutment_15°

Unit: mm, Scale 1.5 : 1

· Abutment screw is included.

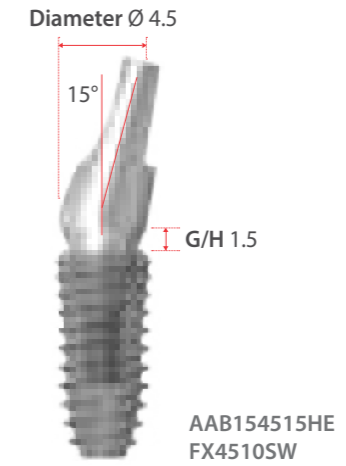

Diameter	G/H	Type	Art. No.
Ø 4.5	1.5	Hex	AAB 15 45 15 HE
	1.5	Non-hex	AAB 15 45 15 NE
	2.5	Hex	AAB 15 45 25 HE
	2.5	Non-hex	AAB 15 45 25 NE
	3.5	Hex	AAB 15 45 35 HE
	3.5	Non-hex	AAB 15 45 35 NE

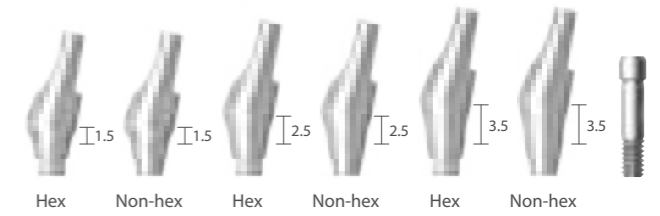

Diameter	G/H	Type	Art. No.
Ø 5.5	1.5	Hex	AAB 15 55 15 HE
	1.5	Non-hex	AAB 15 55 15 NE
	2.5	Hex	AAB 15 55 25 HE
	2.5	Non-hex	AAB 15 55 25 NE
	3.5	Hex	AAB 15 55 35 HE
	3.5	Non-hex	AAB 15 55 35 NE

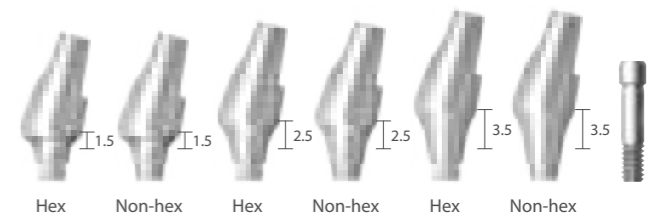

※ Note: It is recommended to keep the torque level at 25~30 N·cm to tighten the angled abutment with fixture.

Angled Abutment_25°

Unit: mm, Scale 1.5 : 1

• Abutment screw is included.

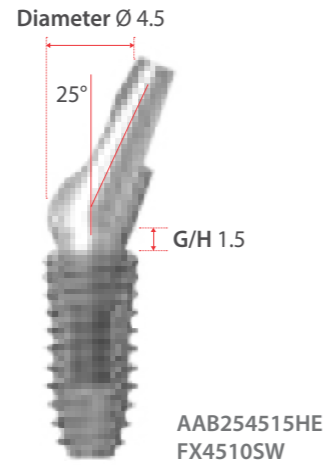

Diameter	G/H	Type	Art. No.
Ø 4.5	1.5	Hex	AAB 25 45 15 HE
	1.5	Non-hex	AAB 25 45 15 NE
	2.5	Hex	AAB 25 45 25 HE
	2.5	Non-hex	AAB 25 45 25 NE
	3.5	Hex	AAB 25 45 35 HE
	3.5	Non-hex	AAB 25 45 35 NE

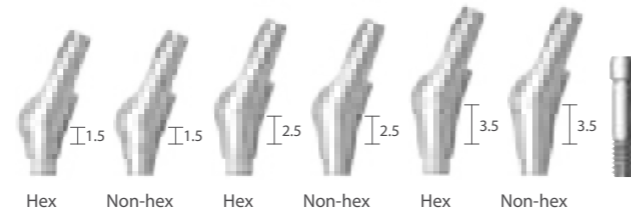

Diameter	G/H	Type	Art. No.
Ø 5.5	1.5	Hex	AAB 25 55 15 HE
	1.5	Non-hex	AAB 25 55 15 NE
	2.5	Hex	AAB 25 55 25 HE
	2.5	Non-hex	AAB 25 55 25 NE
	3.5	Hex	AAB 25 55 35 HE
	3.5	Non-hex	AAB 25 55 35 NE

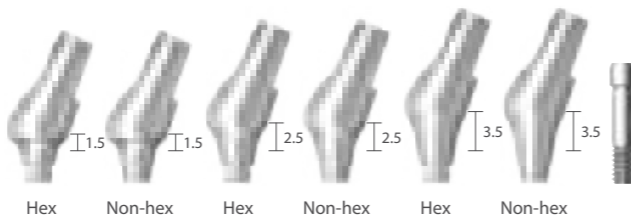

※ Note: It is recommended to keep the torque level at 25~30 N·cm to tighten the angled abutment with fixture.

Direct-Casting Abutment

Unit: mm, Scale 1.5 : 1

• Abutment screw is included.

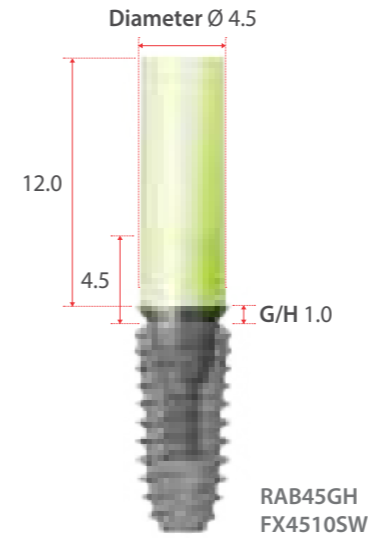

Gold

Diameter	G/H	Type	Art. No.
Ø 4.5	1.0	Hex	RAB 45 GH
		Non-hex	RAB 45 GN

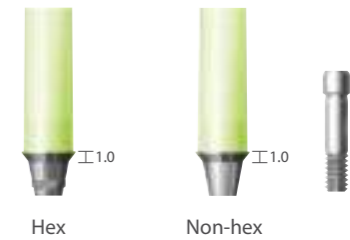

Metal-Casting Abutment

Unit: mm, Scale 1.5 : 1

• Abutment screw is included.

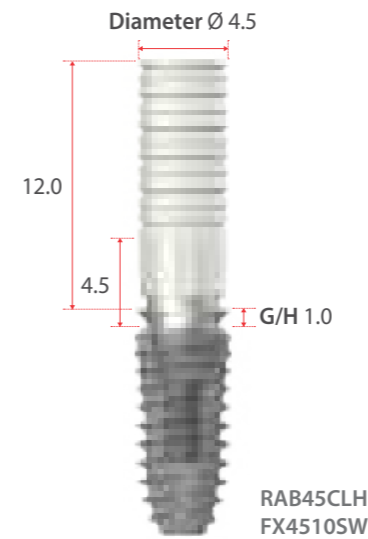

Co-Cr

Diameter	G/H	Type	Art. No.
Ø 4.5	1.0	Hex	RAB 45 CLH
		Non-hex	RAB 45 CLN

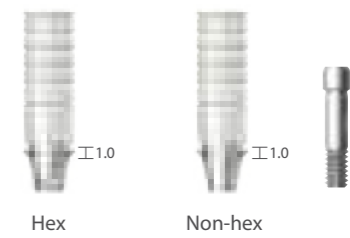

※ Note: It is recommended to keep the torque level at 25~30 N·cm to tighten the direct casting/metal casting abutment with fixture.

Ti-Temporary Abutment

Unit: mm, Scale 1.5 : 1

• Abutment screw is included.

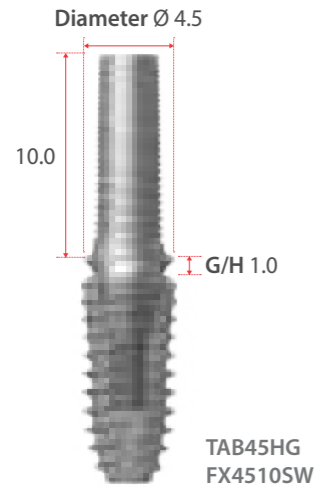

Diameter	G/H	Type	Art. No.
Ø 4.5	1.0	Hex	TAB 45 HG
		Non-hex	TAB 45 NG

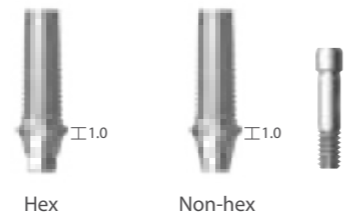

Plastic Temporary Abutment

Unit: mm, Scale 1.5 : 1

• Abutment screw is included.

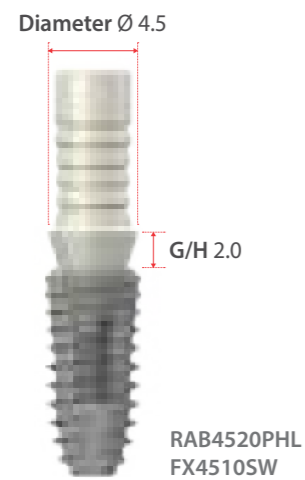

Diameter	G/H	Type	Art. No.
Ø 4.5	2.0	Hex	RAB 45 20 PHL
		Non-hex	RAB 45 20 PNL
Ø 5.5	2.0	Hex	RAB 55 20 PHL
		Non-hex	RAB 55 20 PNL
Ø 6.5	2.0	Hex	RAB 65 20 PHL
		Non-hex	RAB 65 20 PNL

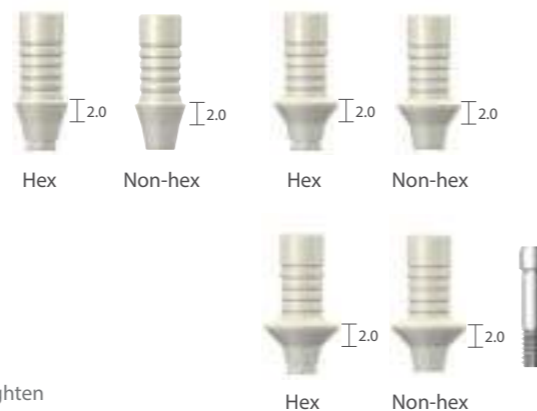

※ Note: It is recommended to keep the torque level at 25~30 N-cm to tighten the temporary abutment with fixture.

Prosthetic Procedure 3

Impression Technique and Restoration Selection

Screw Abutment

Abutment Level Impression

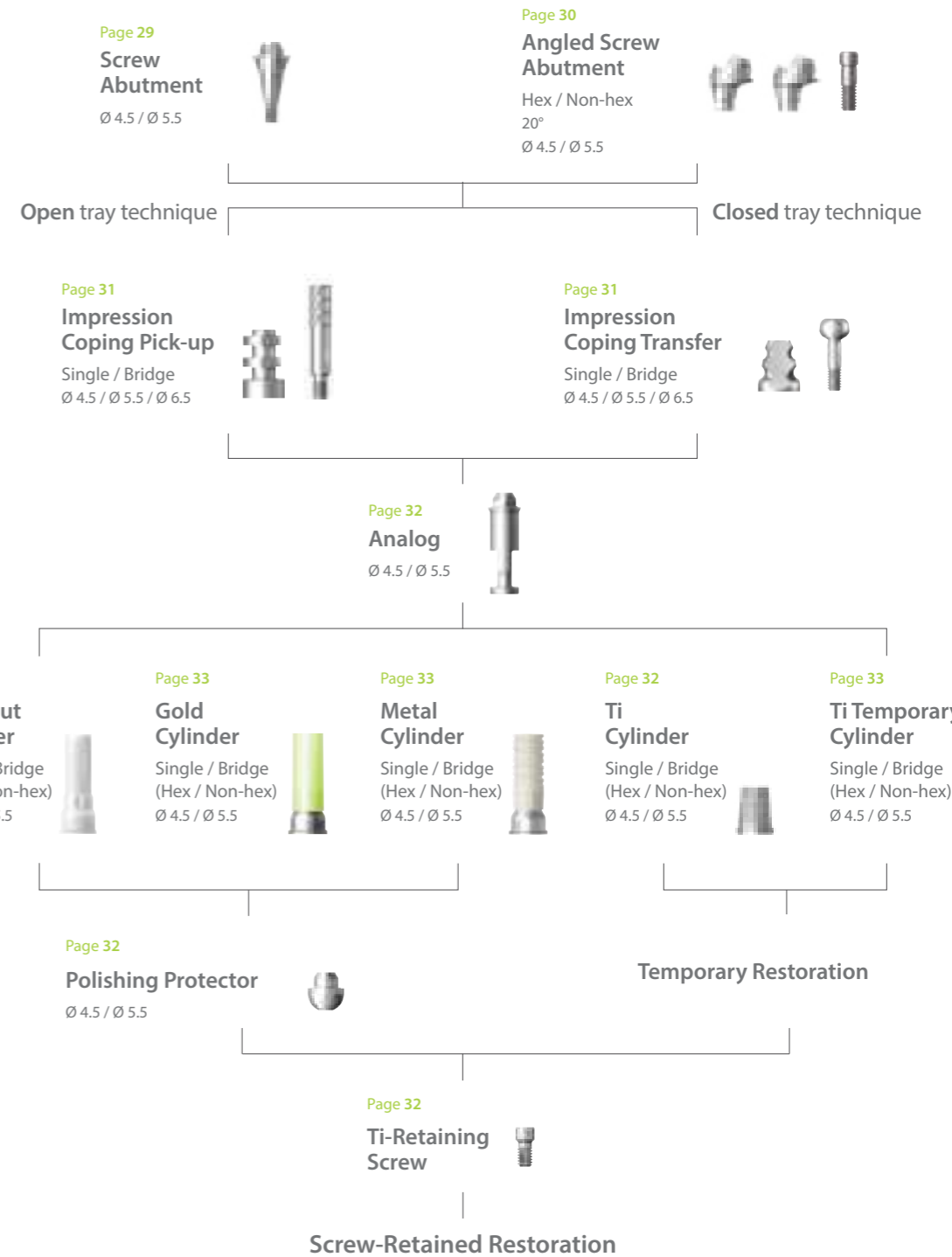

Screw Abutment

Unit: mm, Scale 1.5 : 1

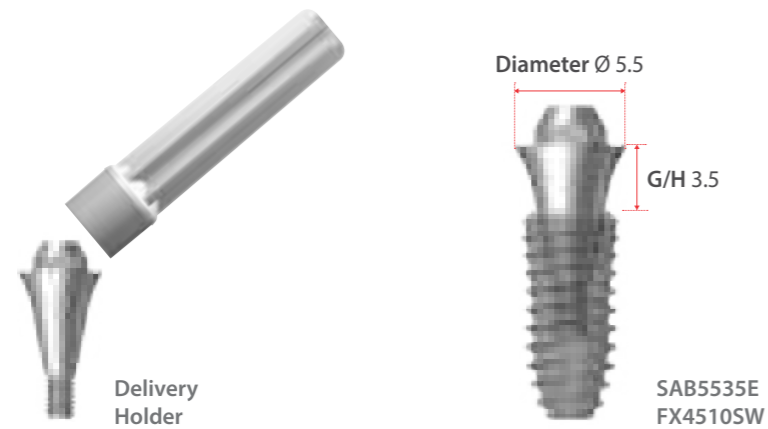

Diameter	G/H	Art. No.
Ø 4.5	1.0	SAB 45 10 E
	1.5	SAB 45 15 E
	2.5	SAB 45 25 E
	3.5	SAB 45 35 E
	4.5	SAB 45 45 E
	5.5	SAB 45 55 E

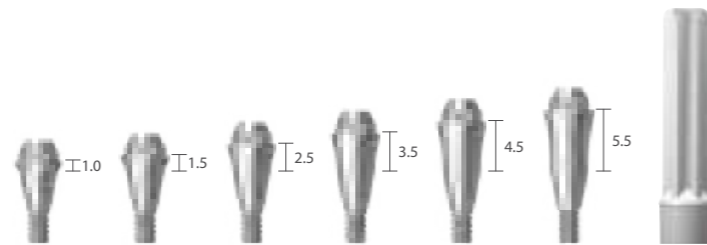

Diameter	G/H	Art. No.
Ø 5.5	1.5	SAB 55 15 E
	2.5	SAB 55 25 E
	3.5	SAB 55 35 E
	4.5	SAB 55 45 E
	5.5	SAB 55 55 E

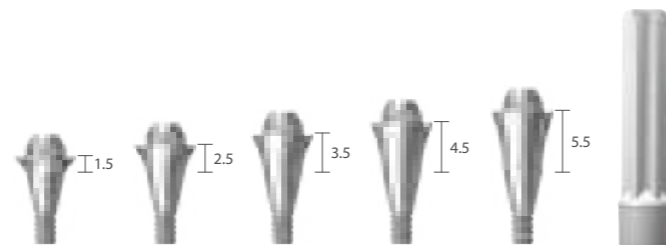

※ Note: It is recommended to keep the torque level at 25~30 N-cm to tighten the screw abutment with fixture.

Angled Screw Abutment

Unit: mm, Scale 1.5 : 1

· Abutment screw is included.



Diameter	G/H	Type	Art. No.
Ø 4.5	1.0	Hex	ASA 45 10 HE
	1.0	Non-hex	ASA 45 10 NE
	2.0	Hex	ASA 45 20 HE
	2.0	Non-hex	ASA 45 20 NE
	3.0	Hex	ASA 45 30 HE
	3.0	Non-hex	ASA 45 30 NE

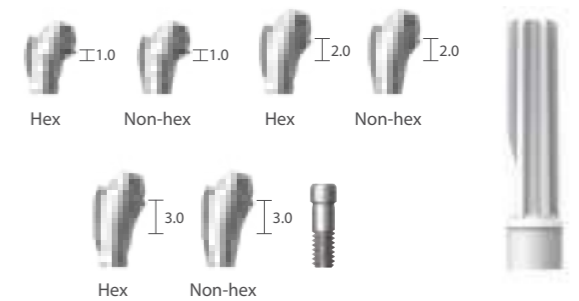

Diameter	G/H	Type	Art. No.
Ø 5.5	1.0	Hex	ASA 55 10 HE
	1.0	Non-hex	ASA 55 10 NE
	2.0	Hex	ASA 55 20 HE
	2.0	Non-hex	ASA 55 20 NE
	3.0	Hex	ASA 55 30 HE
	3.0	Non-hex	ASA 55 30 NE

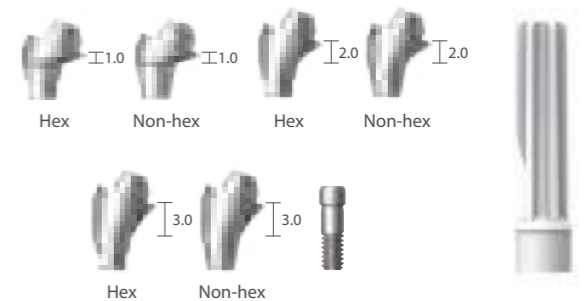

Angled Screw Abutment Screw

Diameter	L	Art. No.
Ø 2.3	7.3	ASASC 20 23

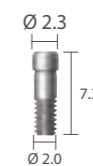

※ Note: It is recommended to keep the torque level at 25~30 N-cm to tighten the angled screw abutment with fixture.

Screw Abutment Impression Components

Unit: mm, Scale 1.5 : 1

Impression Coping Pick-up

Diameter	Type		Art. No.
Ø 4.5	Single	Hex	SPU 45 SL
	Bridge	Non-hex	SPU 45 BL
Ø 5.5	Single	Hex	SPU 55 SL
	Bridge	Non-hex	SPU 55 BL

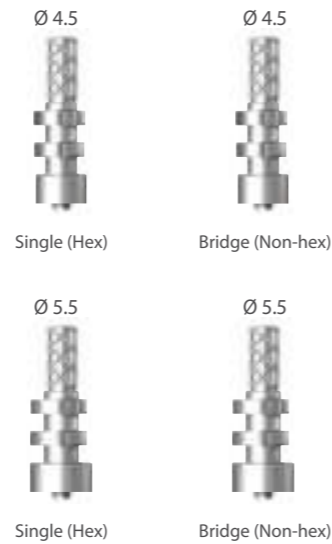

Impression Coping Transfer

Diameter	Type		Art. No.
Ø 4.5	Single	Hex	STF 45 SL
	Bridge	Non-hex	STF 45 BL
Ø 5.5	Single	Hex	STF 55 SL
	Bridge	Non-hex	STF 55 BL

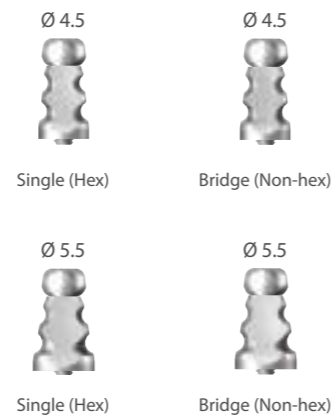

Impression Coping Screw

Type	L	Art. No.
Pick-up	15.0	SPS 09
Transfer	9.0	STS 09

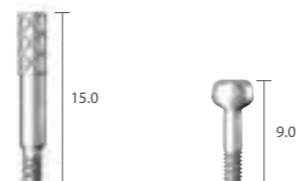

Screw Abutment Impression Components

Unit: mm, Scale 1.5 : 1

Comfort Cap

Diameter	L	Art. No.
Ø 4.5	5.0	SCC 45 L
Ø 5.5		SCC 55 L



Analog

Diameter	L	Art. No.
Ø 4.5	12.0	SAN 45 L
Ø 5.5		SAN 55 L

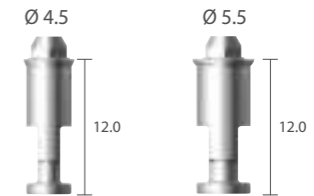

Polishing Protector

Diameter	L	Art. No.
Ø 4.5	4.71	SPP 45 L
Ø 5.5		SPP 55 L



Ti-Retaining Screw

Diameter	L	Art. No.
Ø 2.3	5.0	SRS 18 T

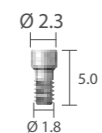

Ti-Cylinder

Diameter	Type		Art. No.
Ø 4.5	Single	Hex	STA 45 S
	Bridge	Non-hex	STA 45 B
Ø 5.5	Single	Hex	STA 55 S
	Bridge	Non-hex	STA 55 B

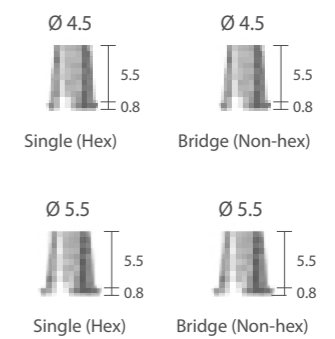

Screw Abutment Impression Components

Unit: mm, Scale 1.5 : 1

Ti-Temporary Cylinder

Diameter	Type		Art. No.
Ø 4.5	Single	Hex	STC 45 SG
	Bridge	Non-hex	STC 45 BG
Ø 5.5	Single	Hex	STC 55 SG
	Bridge	Non-hex	STC 55 BG

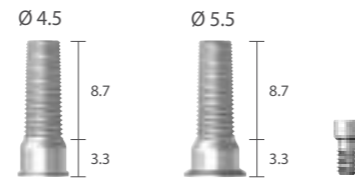

Gold Cylinder

Diameter	Type		Art. No.
Ø 4.5	Single	Hex	SGC 45 SL
	Bridge	Non-hex	SGC 45 BL
Ø 5.5	Single	Hex	SGC 55 SL
	Bridge	Non-hex	SGC 55 BL

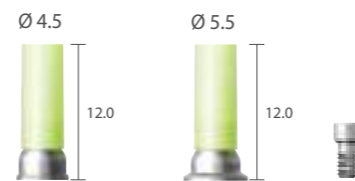

Metal Cylinder | Co-Cr

Diameter	Type		Art. No.
Ø 4.5	Single	Hex	SGC 45 CSL
	Bridge	Non-hex	SGC 45 CBL
Ø 5.5	Single	Hex	SGC 55 CSL
	Bridge	Non-hex	SGC 55 CBL

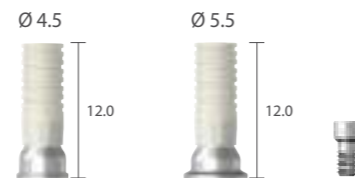

Burn-out Cylinder

Diameter	Type		Art. No.
Ø 4.5	Single	Hex	SBC 45 SL
	Bridge	Non-hex	SBC 45 BL
Ø 5.5	Single	Hex	SBC 55 SL
	Bridge	Non-hex	SBC 55 BL

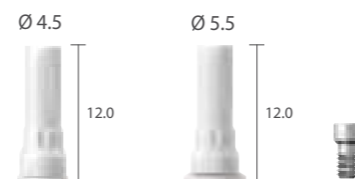











Prosthetic Procedure 4

Impression Technique and Restoration Type

Overdenture Procedure

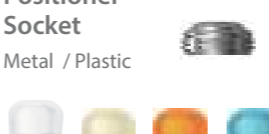
Positioner / Mini Ball / Magnetic Attachment

<p>Page 35 Positioner Abutment Ø 3.5</p> 	<p>Page 36 Mini Ball Abutment Ø 3.5</p> 	<p>Page 38, 39 Magnetic Implant Keeper Dome type / Flat type Ø 4.5 / Ø 5.5</p> 
Abutment Level Impression		
<p>Page 35 Positioner Impression Coping Ø 4.5</p> 	<p>Page 37 Mini Ball Impression Coping Ø 3.5</p> 	
<p>Page 35 Positioner Analog Ø 3.5</p> 	<p>Page 37 Mini Ball Analog Ø 3.5</p> 	
<p>Page 36 Block Out Spacer Ø 6.5</p> 	<p>Page 37 Socket Spacer Ø 4.05 / Ø 4.85</p> 	
<p>Page 36 Positioner Socket Metal / Plastic</p> 	<p>Page 37 Mini Ball Female Socket / O-ring Ø 4.05 / Ø 4.85</p> 	<p>Page 38, 39 Magnetic Assay Dome type / Flat type Ø 4.5 / Ø 5.5</p> 
Positioner Attachment for Overdenture	Mini Ball and Socket Attachment for Overdenture	Magnetic Attachment for Overdenture

Positioner

Unit: mm, Scale 1.5 : 1

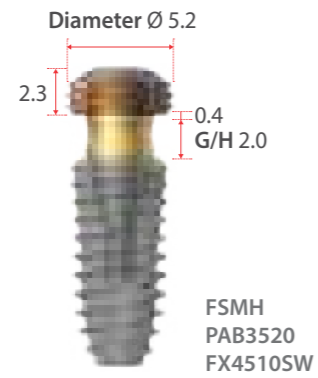

Positioner Abutment

Diameter	G/H	Art. No.
Ø 3.5	1.0	PAB 35 10
	2.0	PAB 35 20
	3.0	PAB 35 30
	4.0	PAB 35 40
	5.0	PAB 35 50
	6.0	PAB 35 60
	7.0	PAB 35 70

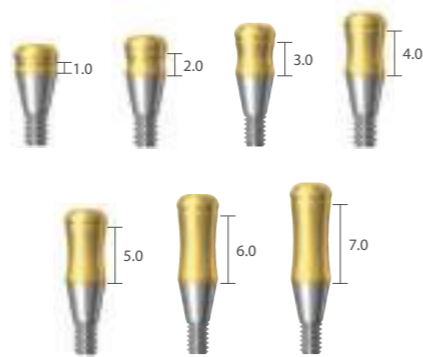

Positioner Impression Coping

Diameter	L	Art. No.
Ø 4.5	4.5	PIC

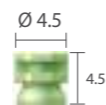

Positioner Analog

Diameter	L	Art. No.
Ø 3.5	12.4	PAN



※ Note: It is recommended to keep the torque level at 25~30 N-cm to tighten the positioner abutment with fixture.

Positioner

Unit: mm, Scale 1.5 : 1

Positioner Socket Set

Type	Art. No.
Tilting type ±10°	FSMHS
Non Tilting type ±5°	FSMHSN

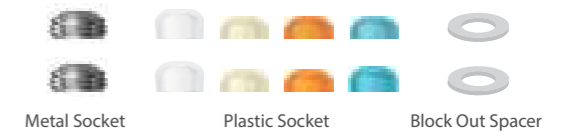

Positioner Metal Socket

Diameter	H	Art. No.
Ø 5.2	2.3	FSMH

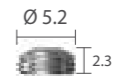

Positioner Abutment

Type	Application	Art. No.	
Tilting type ±10°	Blue	1,000gf	MSHP
	Orange	500gf	MSMP
	Ivory	300gf	MSLP
	White	100gf	MSOP
Non tilting type ±5°	Blue	1,000gf	MSHPN
	Orange	500gf	MSMPN
	Ivory	300gf	MSLPN
	White	100gf	MSOPN

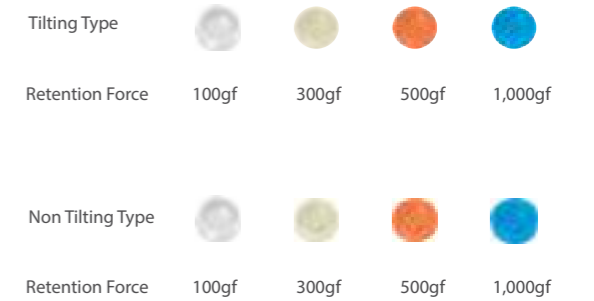

Positioner Block Out Spacer

Diameter	H	Art. No.
Ø 6.5	0.5	FSMH



Positioner Core Tool

XPCT



Mini Ball Attachment

Unit: mm, Scale 1.5 : 1

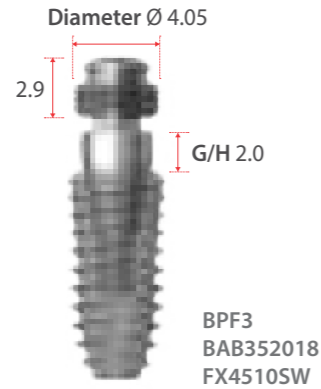

BPF3
BAB352018
FX4510SW

Mini Ball Abutment

Diameter	G/H	Art. No.
Ø 3.3	0	BAB 35 00 18
Ø 3.5	1.0	BAB 35 10 18
Ø 3.5	2.0	BAB 35 20 18
Ø 3.5	3.0	BAB 35 30 18
Ø 3.5	4.0	BAB 35 40 18
Ø 3.5	5.0	BAB 35 50 18

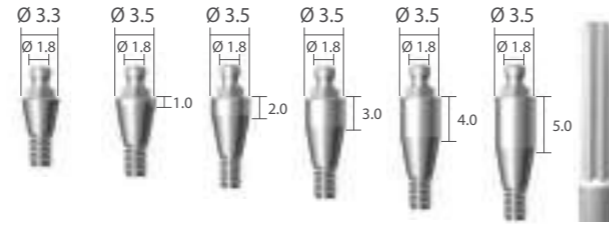

Mini Ball Impression Coping

Diameter	L	Art. No.
Ø 4.0	5.0	GICA

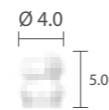

Mini Ball Analog

Diameter	Art. No.
Ø 3.5	BANL



Socket Spacer

Diameter	Art. No.
Ø 4.05	GBIC 3 L
Ø 4.85	GBIC 2 L



Female Socket

Diameter	Retention Force	Art. No.
Ø 4.05	300~500gf	BPF 3
Ø 4.85	500~700gf	BPF 2



※ Note: It is recommended to keep the torque level at 25~30 N-cm to tighten the mini ball abutment with fixture.

Magnetic Attachment_Dome Type

Unit: mm, Scale 1.5 : 1

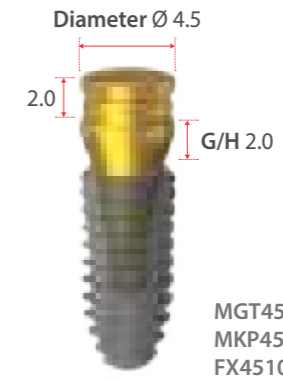

MGT4520D
MKP4520D
FX4510SW

Magnetic Assay

Application	Diameter	H	Art. No.
MKP45D	Ø 4.5	2.0	MGT 45 20 D
MKP55D	Ø 5.5	2.0	MGT 55 20 D

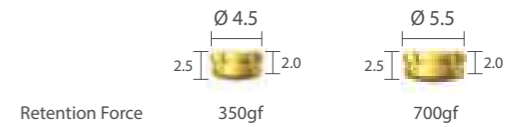

Implant Keeper Diameter

Diameter	G/H	Art. No.
Ø 4.5	1.0	MKP 45 10 D
	2.0	MKP 45 20 D
	3.0	MKP 45 30 D
	4.0	MKP 45 40 D
	5.0	MKP 45 50 D
	6.0	MKP 45 60 D
Ø 5.5	1.0	MKP 55 10 D
	2.0	MKP 55 20 D
	3.0	MKP 55 30 D
	4.0	MKP 55 40 D
	5.0	MKP 55 50 D
	6.0	MKP 55 60 D

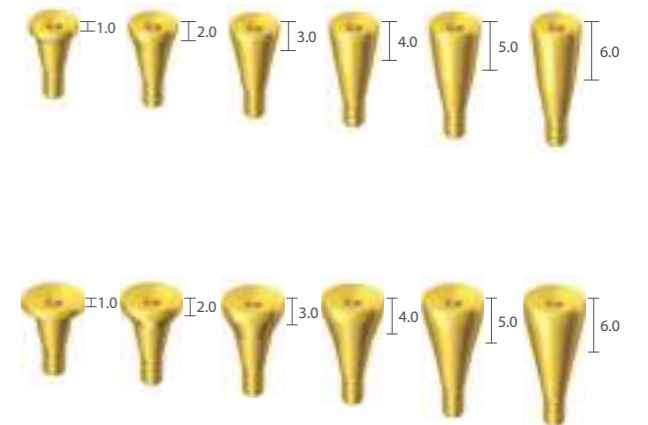

※ Note: It is recommended to keep the torque level at 25~30 N-cm to tighten the magnetic abutment with fixture.

Magnetic Attachment_Flat Type

Unit: mm, Scale 1.5 : 1

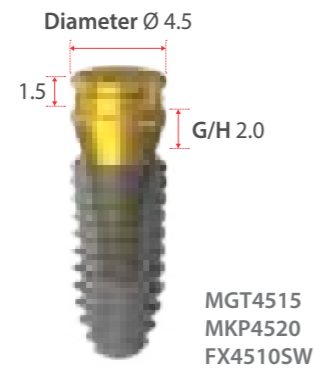

Magnetic Assay

Application	Diameter	H	Art. No.
MKP 45	Ø 4.5	1.5	MGT 45 15
	Ø 4.5	2.0	MGT 45 20
MKP 55	Ø 5.5	1.5	MGT 55 15
	Ø 5.5	2.0	MGT 55 20



Implant Keeper Diameter

Diameter	G/H	Art. No.
Ø 4.5	1.0	MKP 45 10
	2.0	MKP 45 20
	3.0	MKP 45 30
	4.0	MKP 45 40
	5.0	MKP 45 50
	6.0	MKP 45 60
Ø 5.5	1.0	MKP 55 10
	2.0	MKP 55 20
	3.0	MKP 55 30
	4.0	MKP 55 40
	5.0	MKP 55 50
	6.0	MKP 55 60

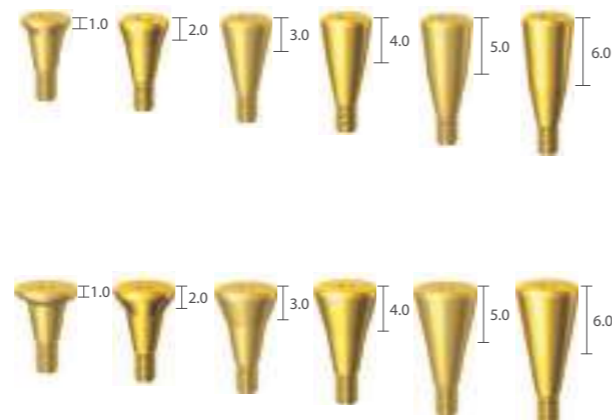

Surgical Kit_Full

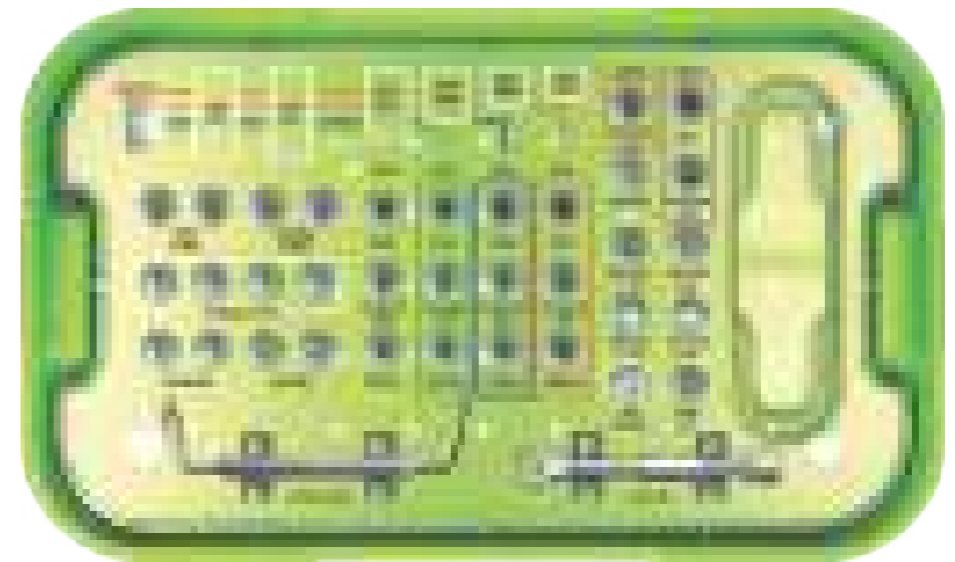

SuperLine Surgical Full Kit

UXNF

Kit Includes

First Guide Drill	Second Guide Drill	Final Drill		Hand-piece Adapter	
XLD2229	XLD2235 (Stopper)	XLD2629	XLD2635 (Stopper)	XFD3435	XFD3835
XFD4335	XFD4835	XFD5831	XFA27H	XFA32H	
Parallel Pin		Countersink		Ratchet Adapter	
XPP162220T	XCS3629SW	XCS4029SW	XCS4529SW	XCS5029SW	XCS6029SW
XCS7029SW	XFA26W	XFA32W	Hex Driver		Drill Extension
XFD3429	XFD3829	XFD4329	XFD4829	XHD26T	XDE
MF Path Pin	Final Drill(s)		Depth Gauge		Ratchet
XMFP2	XFD3429	XFD3829	XFD4329	XFD4829	XDGL
					XRCA1

※ Note: It is recommended to keep the torque level at 25~30 N·cm to tighten the magnetic abutment with fixture.

Surgical Kit_Standard

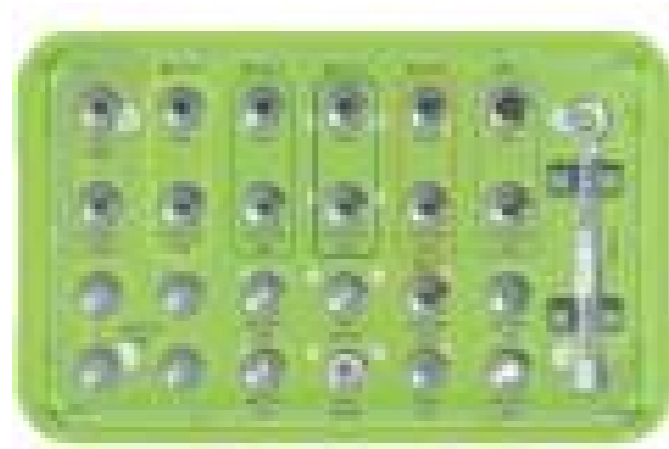

Surgical Kit_Short Implant

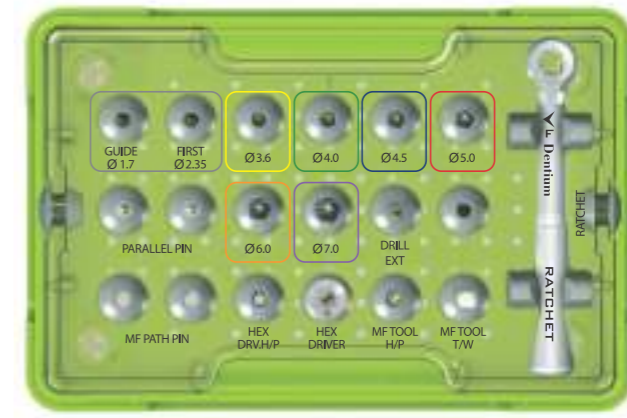

SuperLine Surgical Standard Kit

UXNS

Kit Includes



SuperLine Short Implant Surgical Kit

XSIK

Kit Includes

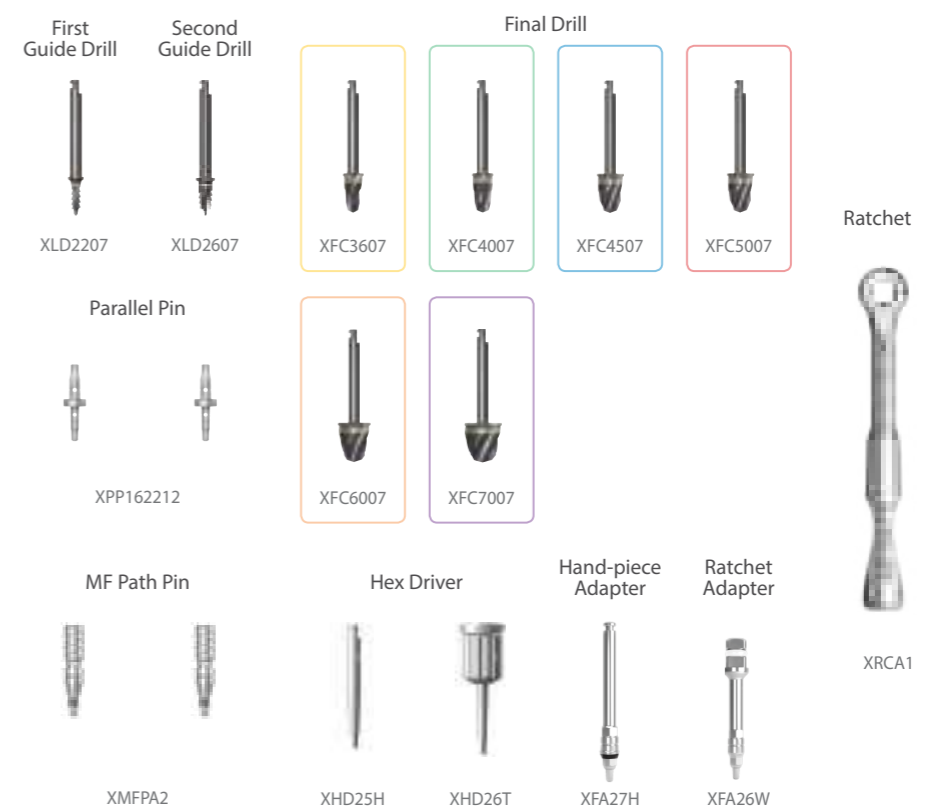

Drill Stopper Kit

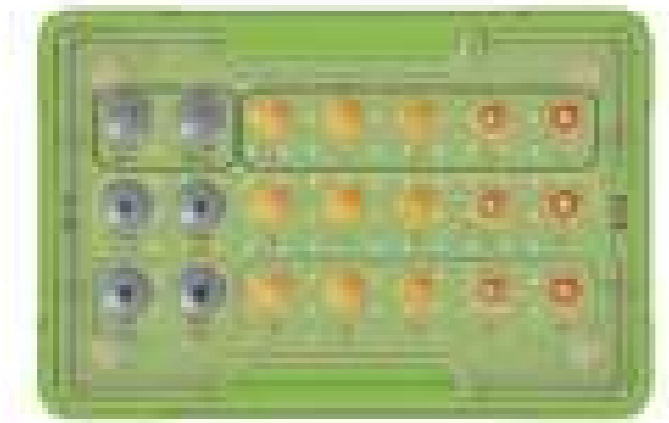

Drill Stopper Kit

XDS

Kit Includes

<p>Guide Drill Stopper First Second</p> <p>XLD2235 XLD2635</p>	<p>Stopper - First Guide Drill, Second Guide Drill</p> <p>XLDST06 XLDST08 XLDST10 XLDST12 XLDST14</p>
<p>Final Drill Stopper 34 38</p> <p>XFD3435 XFD3835</p>	<p>Stopper - Final Drill / 34, 38</p> <p>XFDST06 XFDST08 XFDST10 XFDST12 XFDST14</p>
<p>Final Drill Stopper 43 48</p> <p>XFD4335 XFD4835</p>	<p>Stopper - Final Drill / 43, 48</p> <p>XFDST06L XFDST08L XFDST10L XFDST12L XFDST14L</p>

Surgical Instruments

Unit: mm, Scale 1 : 1

First Guide Drill

Diameter	L	Art. No.
Ø 2.2	26	XLD 22 07
	29	XLD 22 29
	31	XLD 22 31
	33	XLD 22 33
	35	XLD 22 35
	41	XLD 22 41

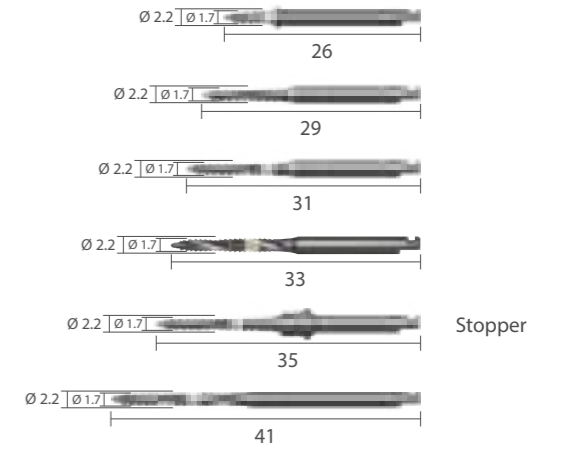

Second Guide Drill

Diameter	L	Art. No.
Ø 2.6	26	XLD 26 07
	29	XLD 26 29
	31	XLD 26 31
	33	XLD 26 33
	35	XLD 26 35
	41	XLD 26 41

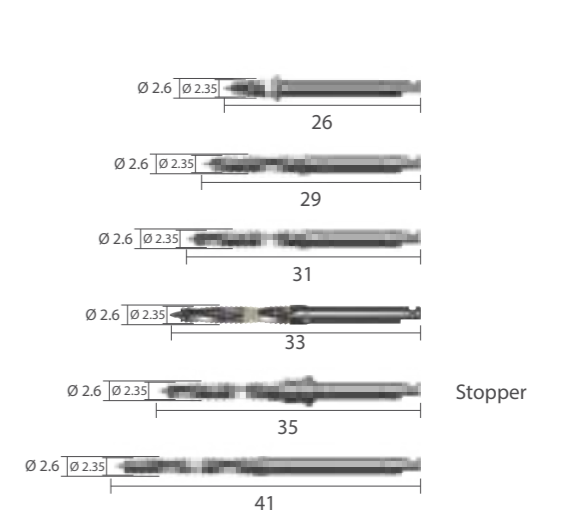

* Note: Drill speed 1,000rpm, 30~45 N-cm with irrigation

Surgical Instruments

Unit: mm, Scale 1 : 1

Final Drill



Diameter	L	Art. No.
Ø 2.9	29	XFD 34 29
Ø 3.35		XFD 38 29
Ø 3.85		XFD 43 29
Ø 4.4		XFD 48 29
Ø 5.4		XFD 58 29 SW

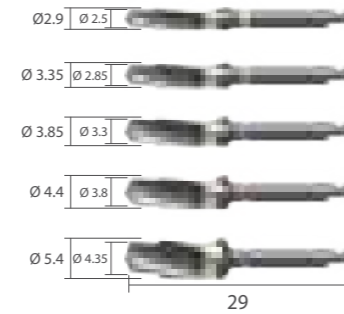

Final Drill



Diameter	L	Art. No.
Ø 2.9	31	XFD 34 31
Ø 3.35		XFD 38 31
Ø 3.85		XFD 43 31
Ø 4.4		XFD 48 31
Ø 5.4		XFD 58 31

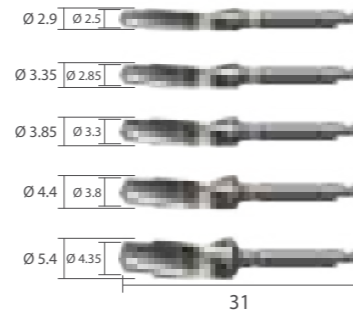

Final Drill



Diameter	L	Art. No.
Ø 2.9	33	XFD 34 33
Ø 3.35		XFD 38 33
Ø 3.85		XFD 43 33
Ø 4.4		XFD 48 33

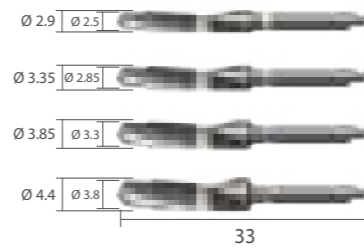

※ Note: Drill speed 1,000rpm, 30~45 N-cm with irrigation

Surgical Instruments

Unit: mm, Scale 1 : 1

Final Drill I Stopper



Diameter	L	Art. No.
Ø 2.9	35	XFD 34 35
Ø 3.35		XFD 38 35
Ø 3.85		XFD 43 35
Ø 4.4		XFD 48 35

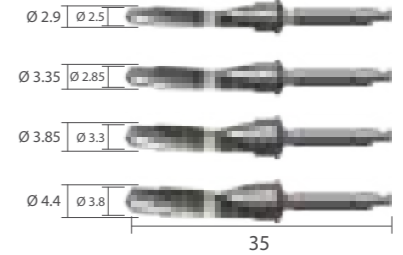

Final Drill



Diameter	L	Art. No.
Ø 2.9	41	XFD 34 41
Ø 3.35		XFD 38 41
Ø 3.85		XFD 43 41
Ø 4.4		XFD 48 41

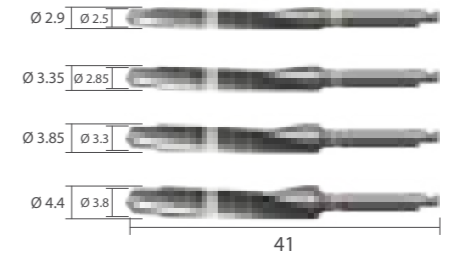

Harvest Drill I Stopper



Diameter	L	Art. No.
Ø 2.85	35	XFH 34 35
Ø 3.3		XFH 38 35
Ø 3.85		XFH 43 35
Ø 4.4		XFH 48 35

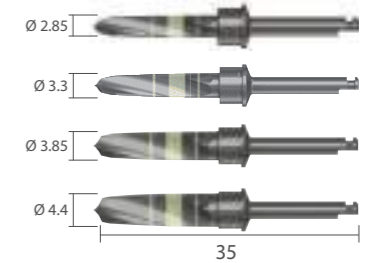

Final Drill I For Short Drill



Diameter	L	Art. No.
Ø 3.6	27	XFC 36 07
Ø 4.0		XFC 40 07
Ø 4.5		XFC 45 07
Ø 5.0		XFC 50 07
Ø 6.0		XFC 60 07
Ø 7.0		XFC 70 07

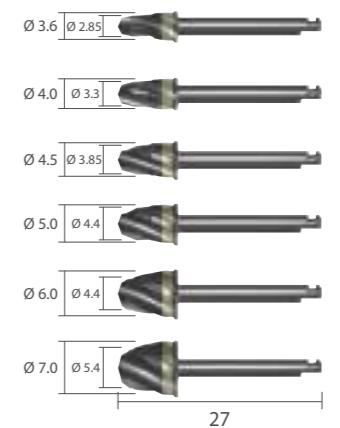

※ Note: Drill speed 1,000rpm, 30~45 N-cm with irrigation

Surgical Instruments

Unit: mm, Scale 1 : 1

Countersink



Diameter	L	Art. No.
Ø 3.6	29	XCS 36 29 SW
Ø 4.0	29	XCS 40 29 SW
Ø 4.5	29	XCS 45 29 SW
Ø 5.0	29	XCS 50 29 SW
Ø 6.0	27	XCS 60 29 SW
Ø 7.0	27	XCS 70 29 SW

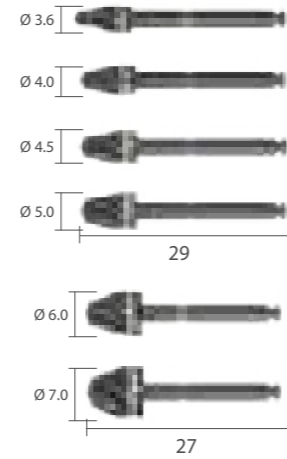

Condensing Drill



Diameter	L	Art. No.
Ø 3.6	33	XCD 36 33
Ø 4.0	33	XCD 40 33
Ø 4.5	33	XCD 45 33
Ø 5.0	33	XCD 50 33
Ø 6.0	31	XCD 60 31
Ø 7.0	31	XCD 70 31

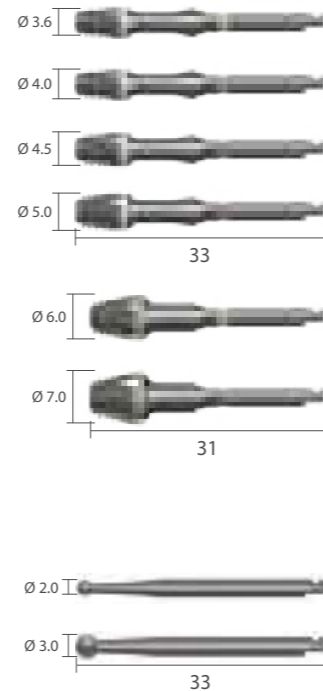

Round Bur

Diameter	L	Art. No.
Ø 2.0	33	XRB 20 33
Ø 3.0		XRB 30 33

※ Note: 1. Countersink Drill & Round Bur speed 1,000rpm, 30~45 N-cm with irrigation
2. Condensing Drill speed 20~60rpm, 30~45 N-cm with irrigation

Surgical Instruments

Unit: mm, Scale 1 : 1

Stopper I For first guide drill, second guide drill

Diameter	Drilling Depth	L	Art. No.
Ø 4.45	14	4.6	XLDST 14
	12	6.6	XLDST 12
	10	8.6	XLDST 10
	08	10.6	XLDST 08
	06	12.6	XLDST 06
	04	14.6	XLDST 04
	02	16.6	XLDST 02

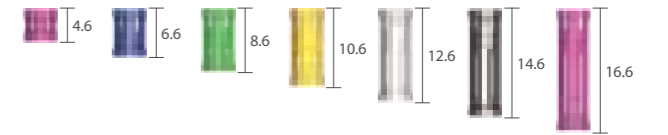

Stopper I For final drill 3435, 3835

Diameter	Drilling Depth	L	Art. No.
Ø 5.14	14	4.6	XFDST 14
	12	6.6	XFDST 12
	10	8.6	XFDST 10
	08	10.6	XFDST 08
	06	12.6	XFDST 06
	04	14.6	XFDST 04
	02	16.6	XFDST 02

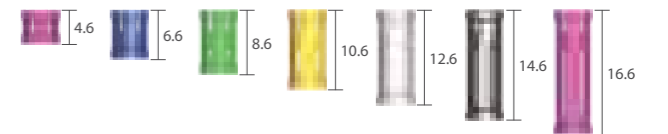

Stopper I For final drill 4335, 4835

Diameter	Drilling Depth	L	Art. No.
Ø 5.14	14	4.6	XFDST 14 L
	12	6.6	XFDST 12 L
	10	8.6	XFDST 10 L
	08	10.6	XFDST 08 L
	06	12.6	XFDST 06 L
	04	14.6	XFDST 04 L
	02	16.6	XFDST 02 L

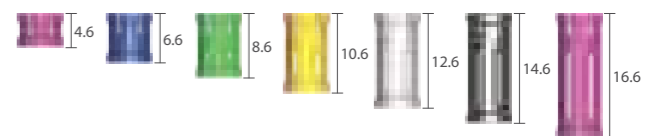

Surgical Instruments

Unit: mm, Scale 1 : 1

Adapter | Hex 2.5mm

Diameter	L	Art. No.
Hand-piece	27	XFA 27 H
	30	XFA 30 H
	32	XFA 32 H
Ratchet	24	XFA 24 W
	26	XFA 26 W
	29	XFA 29 W
	32	XFA 32 W

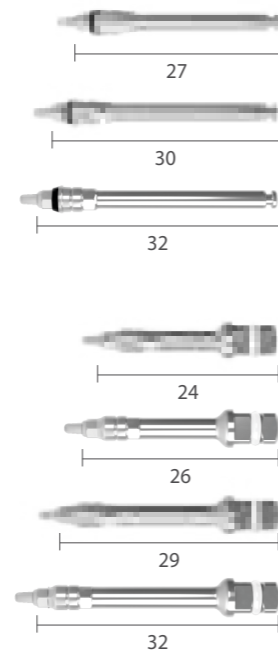

Parallel Pin | For first guide drill, second guide drill

Diameter	L	Art. No.
Ø 1.6	15.5	XPP 162212
	20	XPP 162220 T
	26	XPP 162226 T

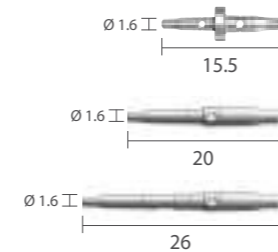

Path Pin

Diameter	L	Art. No.
Ø 1.6	18.6	XMFP A 2

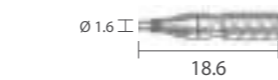

Slot Driver

Type	L	Art. No.
Ratchet	17	SDA 17 R
	25	SDA 25 R

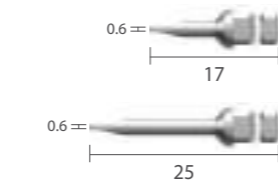

Surgical Instruments

Unit: mm, Scale 1 : 1

Hex Driver | Hex 1.28mm

Type	L	Art. No.
Hand-piece	25	XHD 25 H
	21	XHD 21 W
Ratchet	25	XHD 25 W
	27	XHD 27 W
Manual	26	XHD 26 T
	30	XHD 30 T

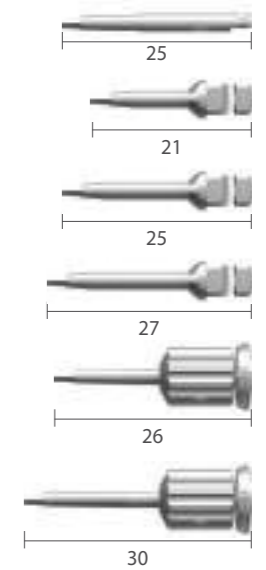

Angled Hex Driver

Type	L	Art. No.
Hand-piece	25	XAD 25 H
	21	XAD 21 W
Ratchet	25	XAD 25 W
	27	XAD 27 W
Manual	26	XAD 26 T
	30	XAD 30 T

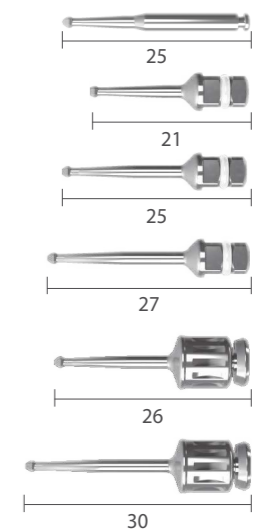

Drill Extension

Diameter	L	Art. No.
Ø 3.0	26	XDE

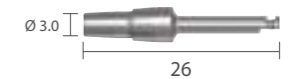

Driver

Type	Diameter	Art. No.
Manual	Ø 12.0	XHDHT

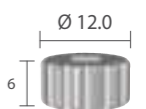

Surgical Instruments

Unit: mm, Scale 1 : 1

Screw & Ball Abutment Adapter

Type	L	Art. No.
Hand-piece	20	XMAA 1
Ratchet	21	XMA 21 W

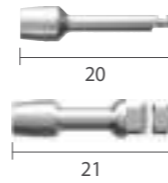

Mini Ball Abutment Adapter

Type	L	Art. No.
Ratchet	21	IPST 21 W



Ratchet

Scale 0.7 : 1

XRCA 1



Torque Wrench

Scale 0.7 : 1

XNTW



Depth Gauge

Scale 0.7 : 1

XDGL



※ Note: One side of Depth Gauge measures the osteotomy depth and the other side measures the gingival height from the top of the implant.

Tissue Punch

Diameter	L	Art. No.
Ø 4.0	27	XTS 40

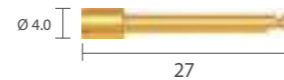

DASK

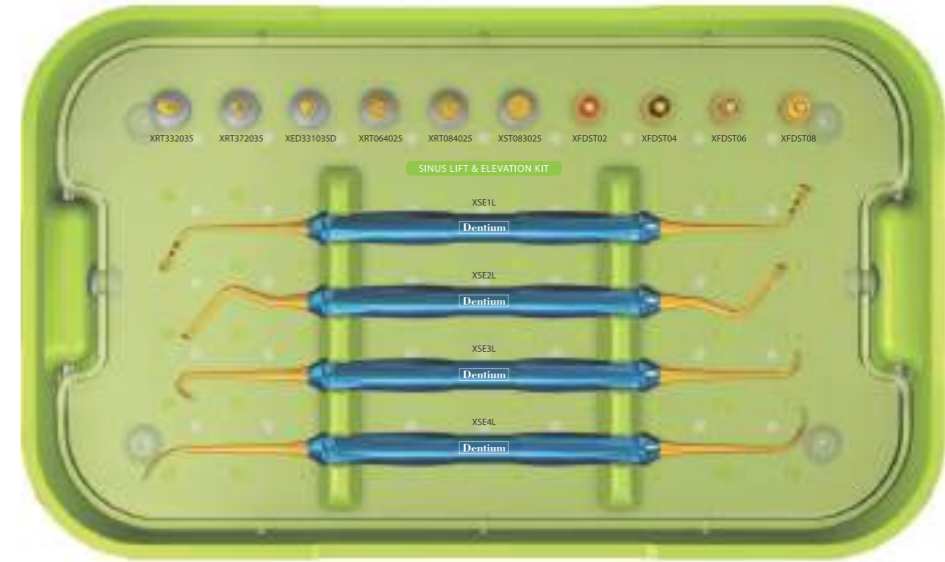

Dentium Advanced Sinus Kit

DASK

Kit Includes



Sinus Elevation Instrument



Sinus Bur Kit

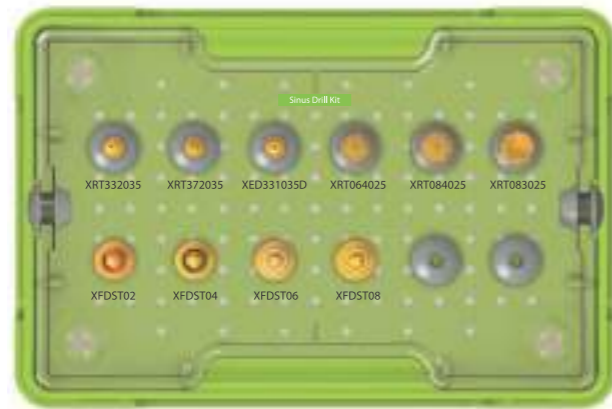

Sinus Bur Kit

SDK

Kit Includes

DASK Drill



Stopper



Sinus Kit

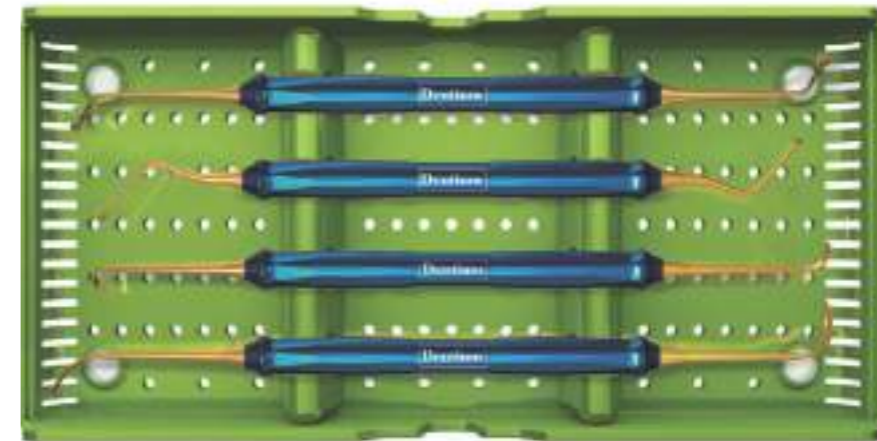

Sinus Bur Kit

XSKL

Kit Includes

Sinus Elevation Instrument



DASK / Sinus Bur Kit

Unit: mm, Scale 1 : 1

DASK Drill

Type	DASK Drill #	Art. No.
Crestal Approach	DASK Drill #1	XRT 33 20 35
	DASK Drill #2	XRT 37 20 35
	DASK Drill #3	XED 33 10 35 D
Lateral Approach	DASK Drill #4	XRT 06 40 25
	DASK Drill #5	XRT 08 40 25
	DASK Drill #6	XST 08 30 25

※ Note: Drill speed 800 to 1,200rpm, 30~45N-cm with irrigation

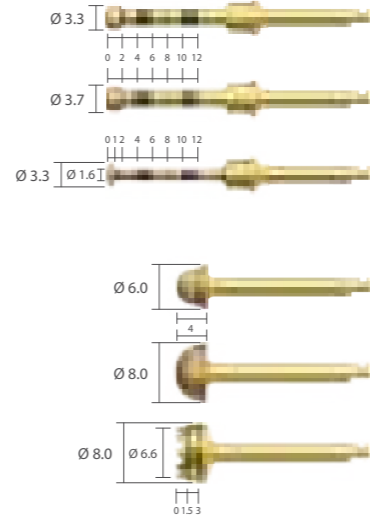

Stopper | For XRT332035, XRT372035, XED331035D

Diameter	Drilling Depth	L	Art. No.
Ø 5.14	08	10.6	XFDST 08
	06	12.6	XFDST 06
	04	14.6	XFDST 04
	02	16.6	XFDST 02

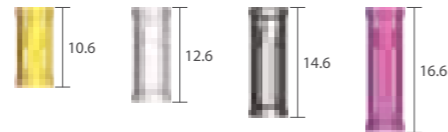

TN Brush

TN Brush

Diameter	Art. No.
Ø0.8	TN-0.8
Ø1.0	TN-1.0
Ø1.3	TN-1.3

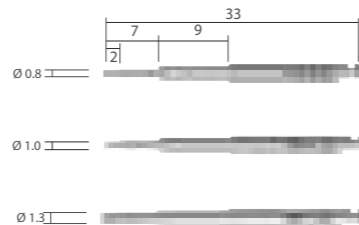

Osteotome Kit

Unit: mm, Scale 1 : 1

Osteotome

Osteotome compresses the bone laterally, providing denser bony interface rather than removing valuable bone from the surgical site.



Osteotome Kit

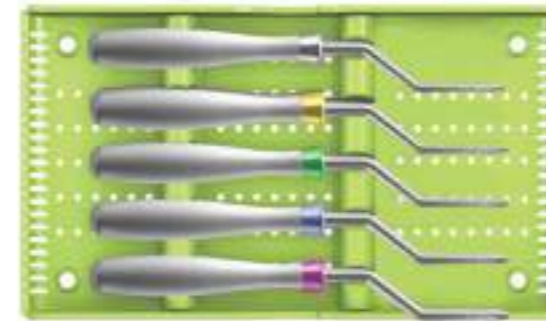

XOFK Type A (Convex)	XOFBK Type B (Concave)
XOF 20 A1	XOF 20 B1
XOF 34 A1	XOF 34 B1
XOF 38 A1	XOF 38 B1
XOF 43 A1	XOF 43 B1
XOF 48 A1	XOF 48 B1

Osteotome | Final drill type | Scale 0.4 : 1

Type	Ø A	Ø B	Art. No.
Type A (Convex)	Ø 1.7	Ø 2.8	XOF 20 A1
	Ø 2.3	Ø 2.8	XOF 34 A1
	Ø 2.7	Ø 3.2	XOF 38 A1
	Ø 2.8	Ø 3.8	XOF 43 A1
	Ø 3.0	Ø 4.3	XOF 48 A1
Type B (Concave)	Ø 1.7	Ø 2.8	XOF 20 B1
	Ø 2.3	Ø 2.8	XOF 34 B1
	Ø 2.7	Ø 3.2	XOF 38 B1
	Ø 2.8	Ø 3.8	XOF 43 B1
	Ø 3.0	Ø 4.3	XOF 48 B1

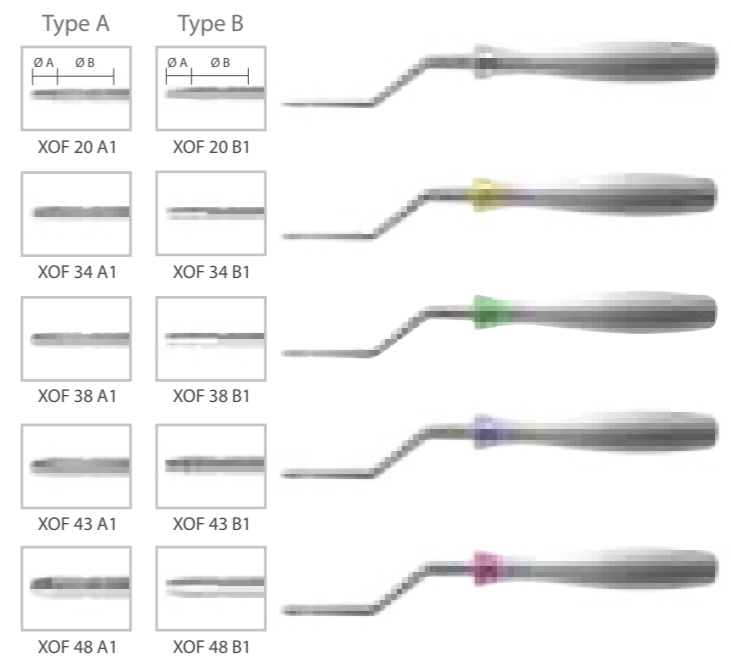

Trephine Kit

Unit: mm, Scale 1 : 1

Trephine Bur

- Excellent fine cutting
- Strong engagement when attaching the trephine to cortical bone
- Cut-outs facilitates ease of harvest retrieval
- 5 scale marks on the Trephine drill from 2mm to 10mm
- Easy harvesting

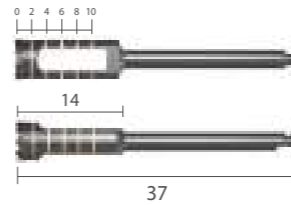

Trephine Kit



XIT

Kit Includes

XTP 24 03	XTP 34 04	XTP 44 05	XTP 54 06
XTP 64 07	XTP 74 08	XTP 84 09	XTP 94 10

Trephine Bur

Outer Diameter	Inner Diameter	Art. No.
Ø 3.0	Ø 2.3	XTP 24 03
Ø 4.0	Ø 3.3	XTP 34 04
Ø 5.0	Ø 4.2	XTP 44 05
Ø 6.0	Ø 5.2	XTP 54 06
Ø 7.0	Ø 6.1	XTP 64 07
Ø 8.0	Ø 7.1	XTP 74 08
Ø 9.0	Ø 8.0	XTP 84 09
Ø 10.0	Ø 9.0	XTP 94 10

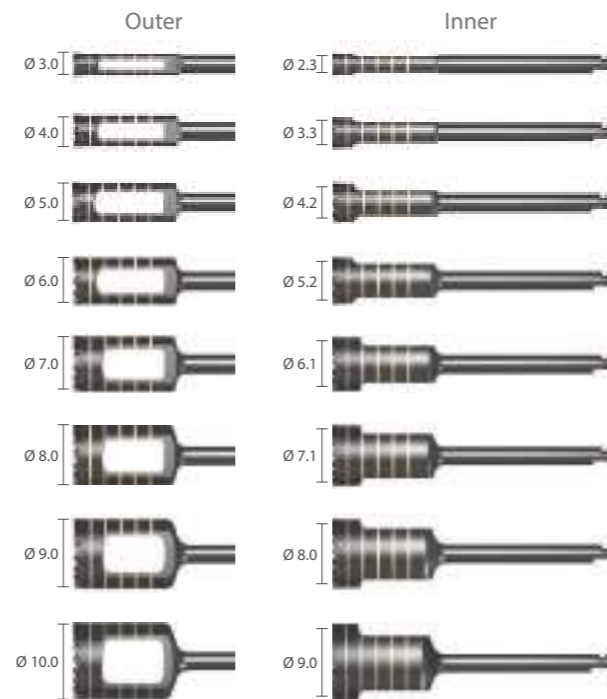

Instrument

Unit: mm, Scale 1 : 1.5

Adapter For screw abutment

Type	Art. No.
Hand-piece	XMAA1
Torque Wrench	XMA 21W

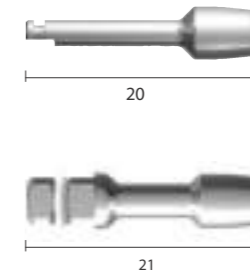

Screw Drill

Diameter	Art. No.
Ø1.2	GMD 1228



Membrane screw insertion tool

Art. No.
GST26H
GST56
GST85
COD

[Unit: mm, Scale 1 : 0.7]

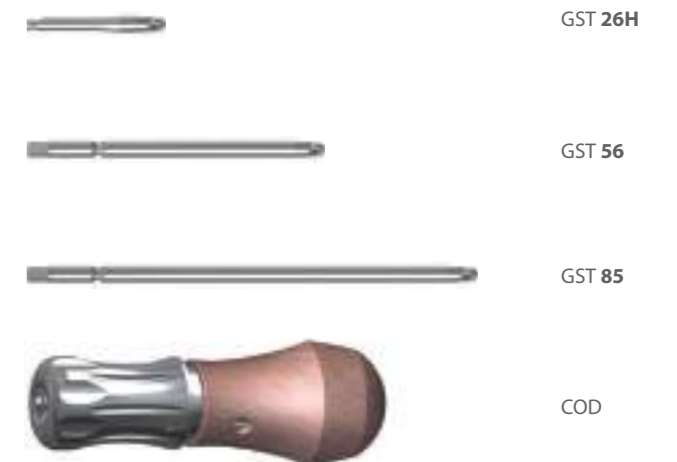

Membrane Pins

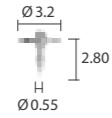

L	Art. No.
2.80	GMT3225



L	Art. No.
125.0	GMNT

Unit: mm, Scale 1 : 2

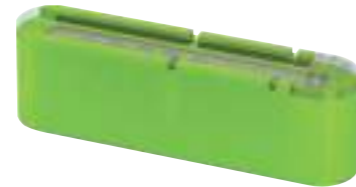

Pin case | Pin 10ea included



Membrane Pin with insertion tool

Membrane Screws

Unit: mm, Scale 1 : 2

Screw

L	Art. No.
2.5	GSC 15 02
4.0	GSC 15 04
6.0	GSC 15 06
8.0	GSC 15 08
10.0	GSC 15 10

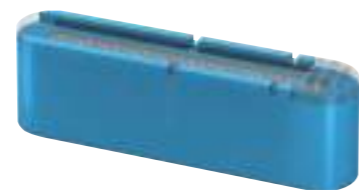
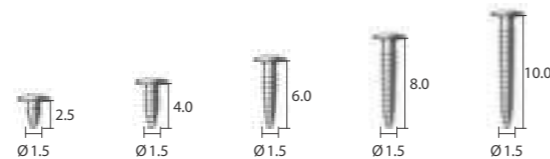

Screw case | Screw 10ea included

Prosthetic Kit

Unit: mm, Scale 1 : 1

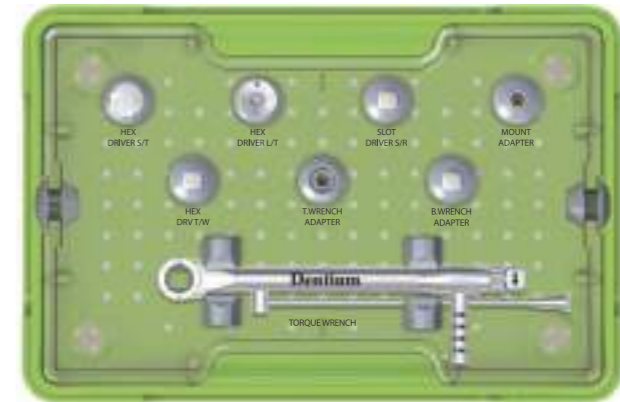

XIP

Hex Driver

Type	L	Art. No.
S/T	15	XHD 15
L/T	30	XHD 30 T
Torque Wrench	25	XHD 25 W



Adapter

Type	L	Art. No.
Torque Wrench	21	XMA 21 W
Mini Ball	21	IPST 21 W
Mount	20	XMAA 1



Slot Driver

SDA 25 R



Torque Wrench

Scale 0.7 : 1

XNTW



Planning Kit

Unit: mm, Scale 1 : 1



XPK

For Combi & Dual Abutment

Diameter	G/H	Art. No.
Ø 4.5	1.5	PDAB 45 15
	2.5	PDAB 45 25
	3.5	PDAB 45 35
	4.5	PDAB 45 45
	5.5	PDAB 45 55
Ø 5.5	1.5	PDAB 55 15
	2.5	PDAB 55 25
	3.5	PDAB 55 35
	4.5	PDAB 55 45
	5.5	PDAB 55 55
Ø 6.5	1.5	PDAB 65 15
	2.5	PDAB 65 25
	3.5	PDAB 65 35
	4.5	PDAB 65 45
	5.5	PDAB 65 55

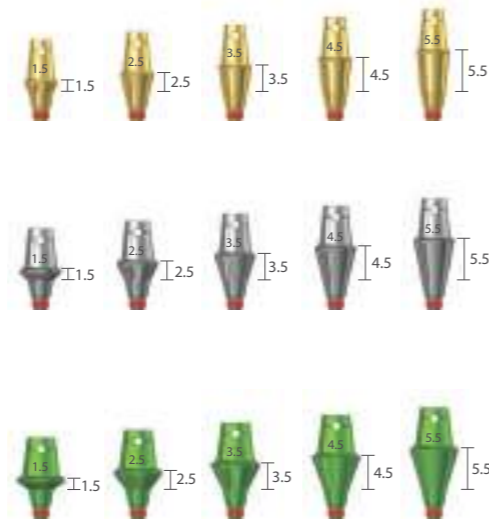

For Angled Abutment

Angled	Diameter	G/H	Art. No.
15°	Ø 4.5	2.0	PAAB 15 45 20
		4.0	PAAB 15 45 40
	Ø 5.5	2.0	PAAB 15 55 20
		4.0	PAAB 15 55 40
25°	Ø 4.5	2.0	PAAB 25 45 20
		4.0	PAAB 25 45 40
	Ø 5.5	2.0	PAAB 25 55 20
		4.0	PAAB25 55 40

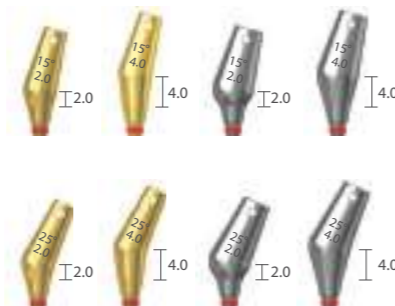

Prosthetic and Laboratory Instrument

Unit: mm, Scale 1 : 1

Hex Driver

Hex	L	Art. No.
1.28	13	XHD 13
	15	XHD 15
	21	XHD 21
	28	XHD 28

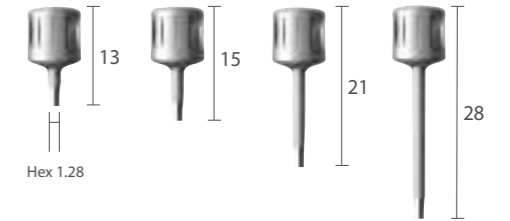

Reamer Guide

Application	Diameter	Art. No.
Combi / Dual Abutment	Ø 4.5	CRG 45 L
	Ø 5.5	CRG 55 L
	Ø 6.5	CRG 65 L

Application	Type	Art. No.
Screw Abutment	Bridge	SRG BL
	Single	SRG SL

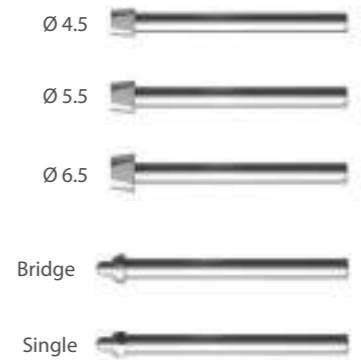

Reamer Handle

Scale 0.5 : 1

CRH



Hand Wrench

XHW



Reamer

Application	Art. No.
Combi / Dual Abutment	CRM
Screw Abutment	SRM



Help Kit

Unit: mm, Scale 1 : 1

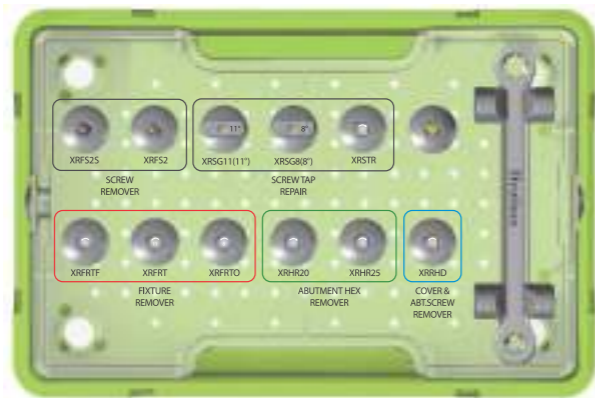

XIH

Screw Remover

L	Art. No.
25	XRFS 2 S
33	XRFS 2

Screw Tap Repair

Type	Art. No.
Tap	XRSTR
11° Guide	XRSG 11
8° Guide	XRSG 8

Fixture Remover

Type	Art. No.
-	XRFRF
11°	XRFRTF
8°	XRFRTO

Abutment Hex Remover

L	Art. No.
20	XRHR 20
25	XRHR 25

Cover & Abutment Screw Remover

L	Art. No.
25	XRRHD

Wrench

XRFRW

Scale 1 : 0.7

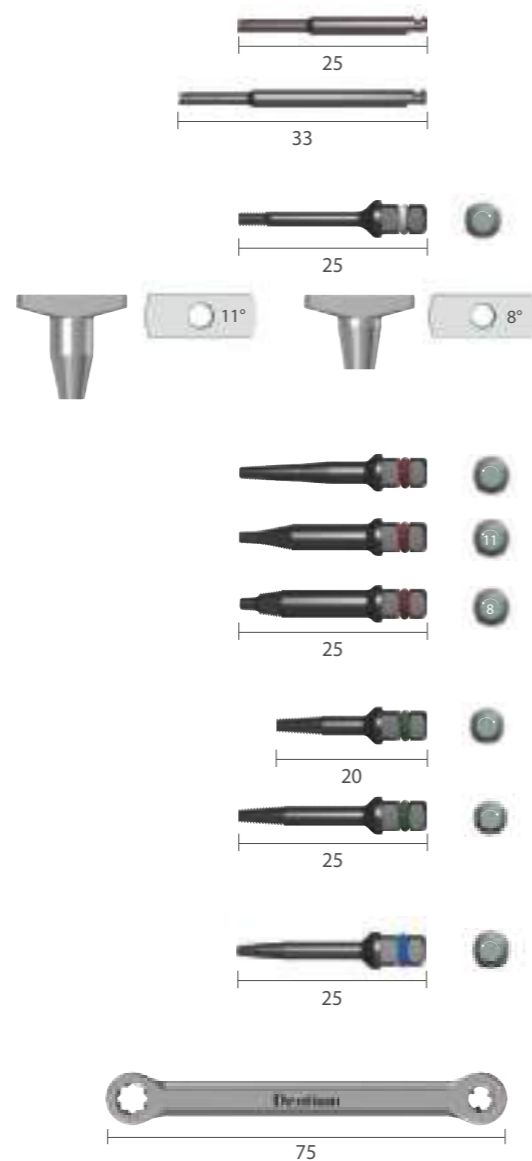

Polymer Guide Kit

Unit: mm, Scale 1 : 1



PGSSK



PGSCK

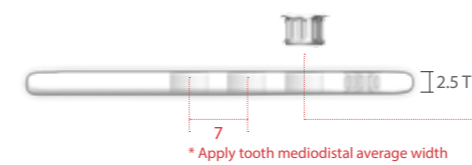
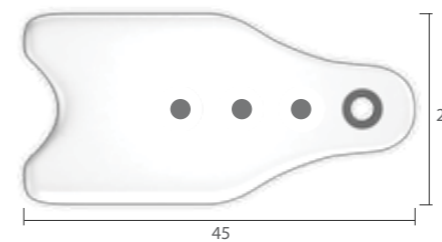
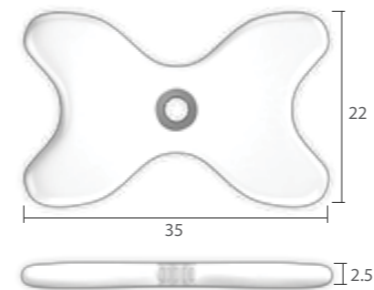

Single Standard (5ea)

T	Art. No.
2.5	XSG 34 35 S

Cantilever Multi-Ready (5ea)

T	Art. No.
2.5	XSG 34 45 C

- Stone Drill  XGD 23 60 (1ea)
- Guide Pin  XGP 34 23 S (5ea)
- Additional Metal Sleeve (for Cantilever Multi-Ready)  XPGS 34 25 A (5ea)

Sinus Kit

Unit: mm, Scale 1 : 1

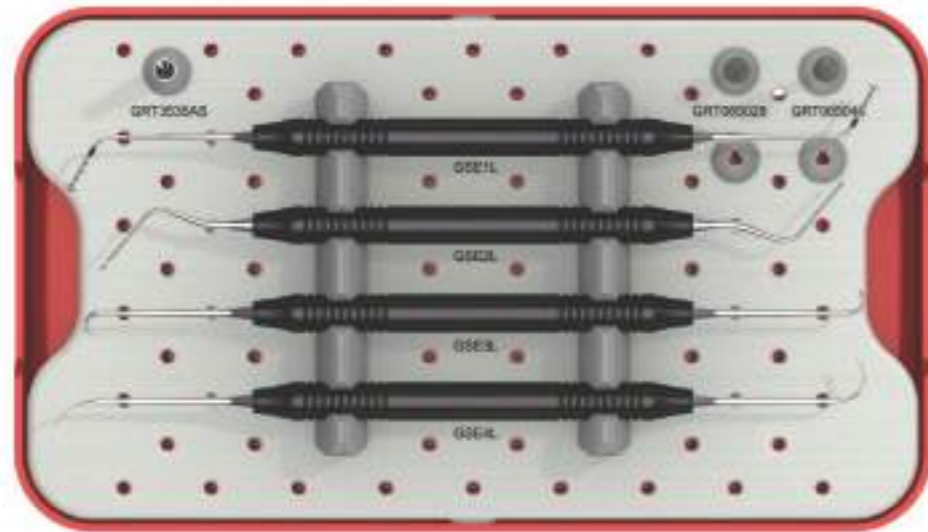

GSEK

Crestal Drill

Diameter	L	Art No.
Ø3.5	35	GRT 35 35 AS



Lateral Drill

Diameter	L	Art No.
Ø6.0	28	GRT 06 50 28
Ø6.0	40	GRT 06 50 40

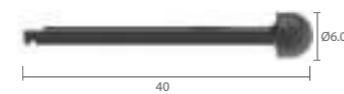
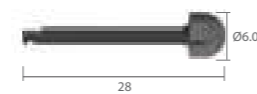

Sinus Curette Scale 1 : 2 / mm



Ridge Expander Kit

Unit: mm, Scale 1 : 1

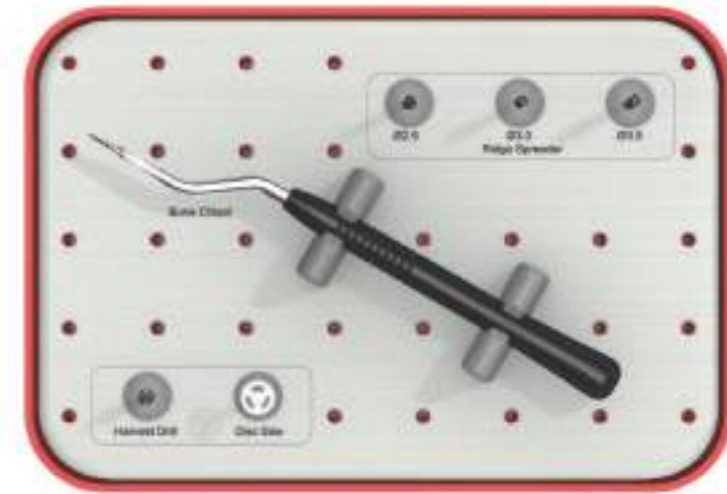

GREK

Ridge Spreader

Diameter	L	Art No.
Ø1.3 / Ø2.5	32	GRS 13 25
Ø1.8 / Ø3.0	32	GRS 18 30
Ø2.3 / Ø3.5	32	GRS 23 35

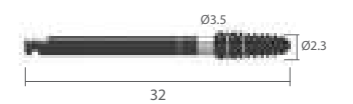
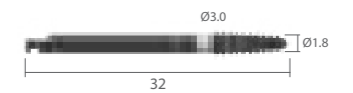
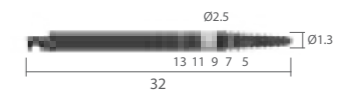

Harvest Drill

Diameter	L	Art No.
Ø3.0	29	GHD 30 29

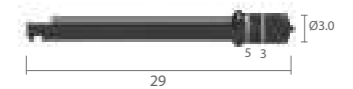

Disc Saw

Diameter	L	Art No.
Ø8.0	25	GDS 80 25

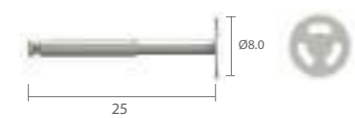

Bone Chisel

Art No.	GBC 18 45 13
---------	--------------

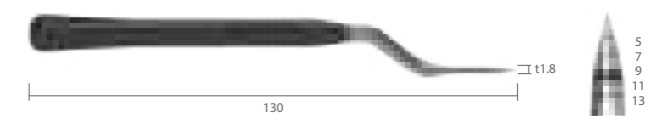

5
7
9
11
13

Implant Guide Kit

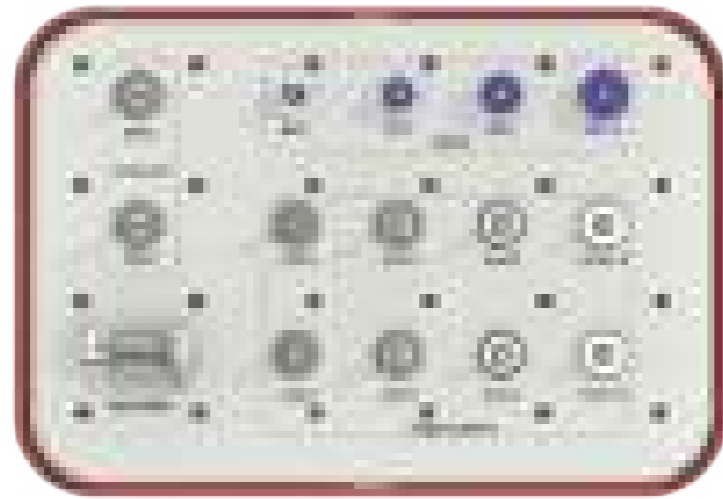

Unit: mm, Scale 1 : 1

GIGK

Guide Drill

Diameter	L	Art No.
Ø2.6	29	GGD 26 29
	35	GGD 26 35

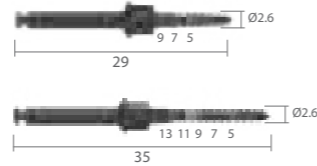

Spacer

Width	Art No.
5.0	GSP 05
7.0	GSP 07
9.0	GSP 09
11.0	GSP 11



Single Guide Pin

Width	Art No.
4.0 / 5.0	GGP 04 05
6.0 / 7.0	GGP 06 07
8.0 / 9.0	GGP 08 09
10.0 / 11.0	GGP 10 11

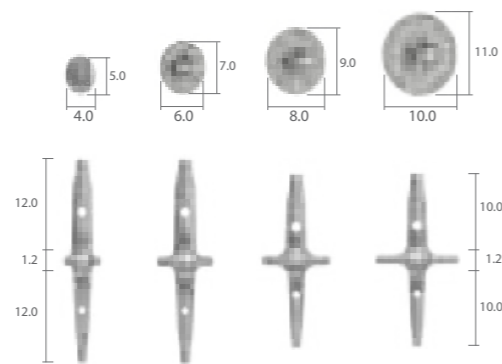

Multi Guide

Art No.	Art No.
	GMG2



Digital Full Kit

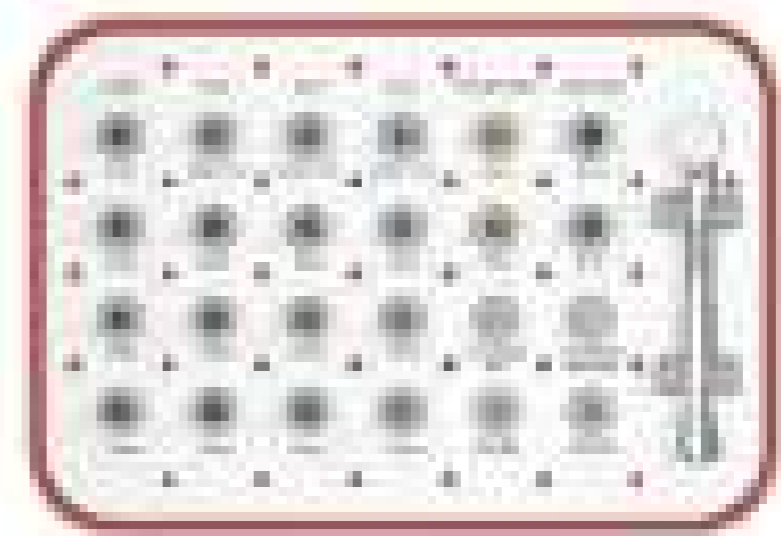

Unit: mm, Scale 1 : 1

XGSFK

SuperLine FX4510SW Guided drilling Sequence

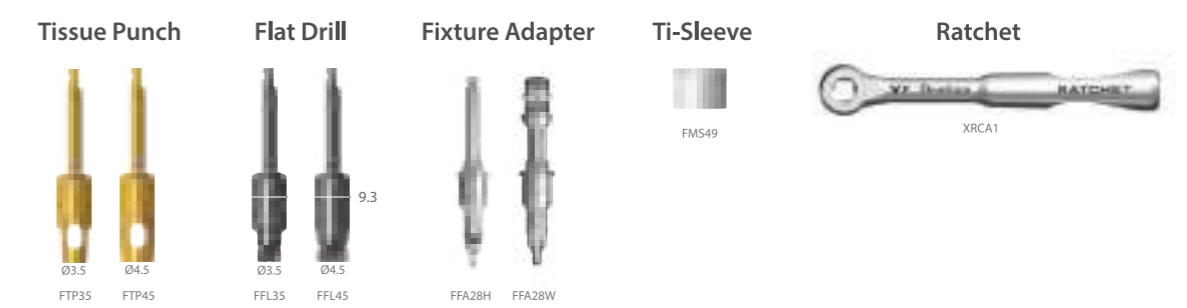
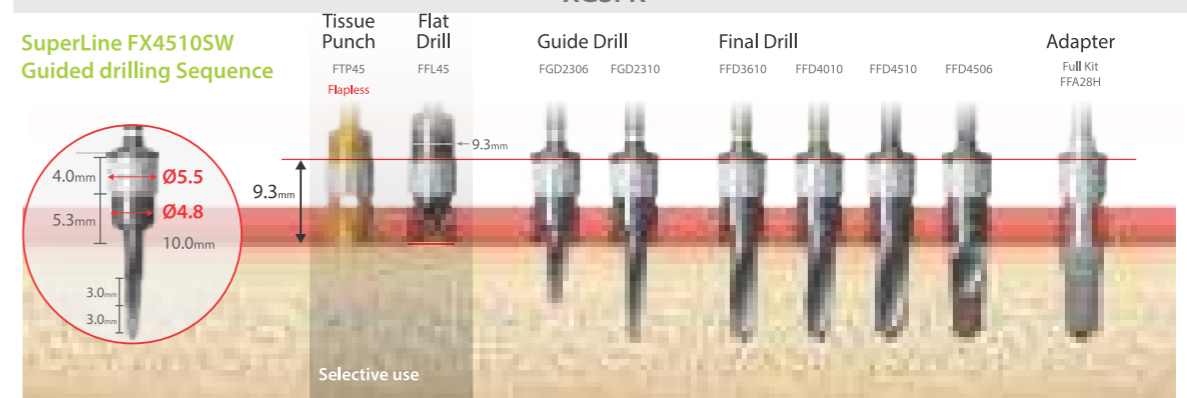

Digital Simple Kit

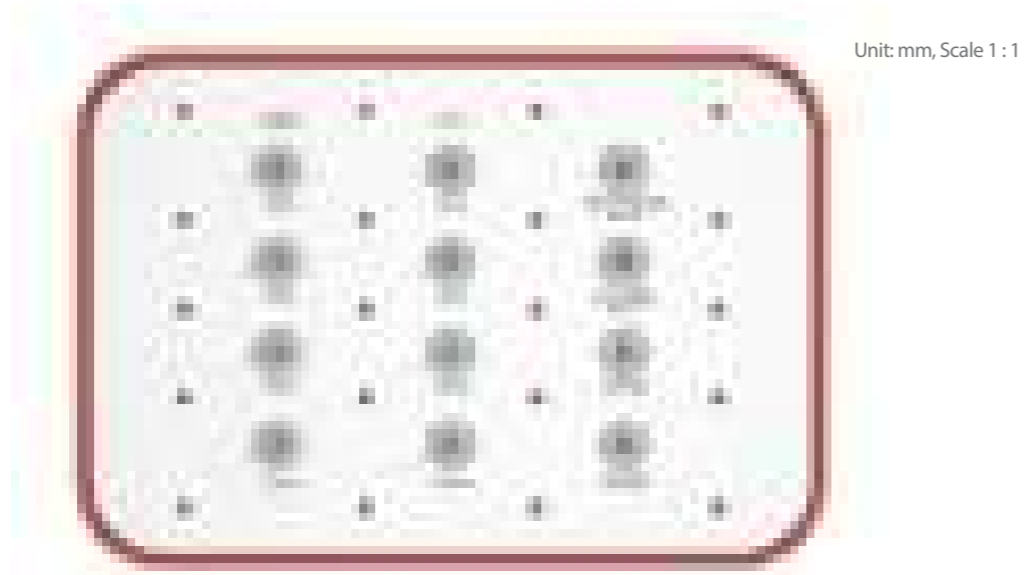

Unit: mm, Scale 1 : 1

XGSSK

SuperLine FX3610SW Guide drilling Sequence

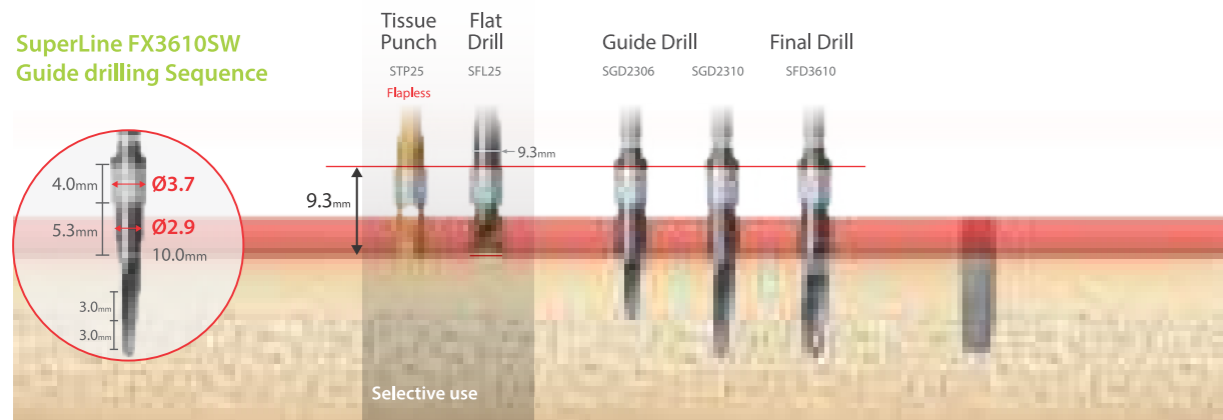

Contents

SURGICAL MANUAL	Surgical Drill Sequence I	70
	Surgical Drill Sequence II	71
	Drilling Depth Guide	72
	Fixture Connection	76
	Installation Procedure & Warnings	77
	Surgical Kit Maintenance	78
PROSTHESIS MANUAL	Understanding the Implant and Prosthesis	80
	Types of Abutment	81
	Dual Abutment	82
	Combi Abutment	83
	Custom / Milling Abutment	84
	Angled Abutment	85
	Direct-Casting / Metal-Casting Abutment	86
	Temporary Abutment	87
	Screw Abutment	88
	Points to Consider in Abutment Selection	89
	Minimum Height Requirement for SuperLine Prosthetic Abutment	90
	Prosthetic Procedure 1	91
	Abutment Level - Dual Abutment	92
	Abutment Level - Combi Abutment	95
	Prosthetic Procedure 2	97
	Fixture Level - [Pick-up Type]_Dual Abutment	98
	Fixture Level - [Transfer Type]_Dual Abutment	101
	Fixture Level - [Transfer Type]_Milling Abutment	104
	Fixture Level - [Pick-up Type]_Angled Abutment	106
	Fixture Level - Direct-Casting Abutment	108
	Fixture Level - Metal-Casting Abutment	109
	Fixture Level - [Pick up Type]_Temporary Abutment	110
	Prosthetic Procedure 3	111
	Abutment Level - [Transfer Type]_Screw Abutment	112
	Cementation Repair Method (SCRIP)	115
	Prosthetic Procedure 4	117
	Positioner	118
	Mini Ball Attachment	121
	Magnetic Attachment	122

Surgical Drill Sequence I

Drilling Sequence Guide (Final Drill)

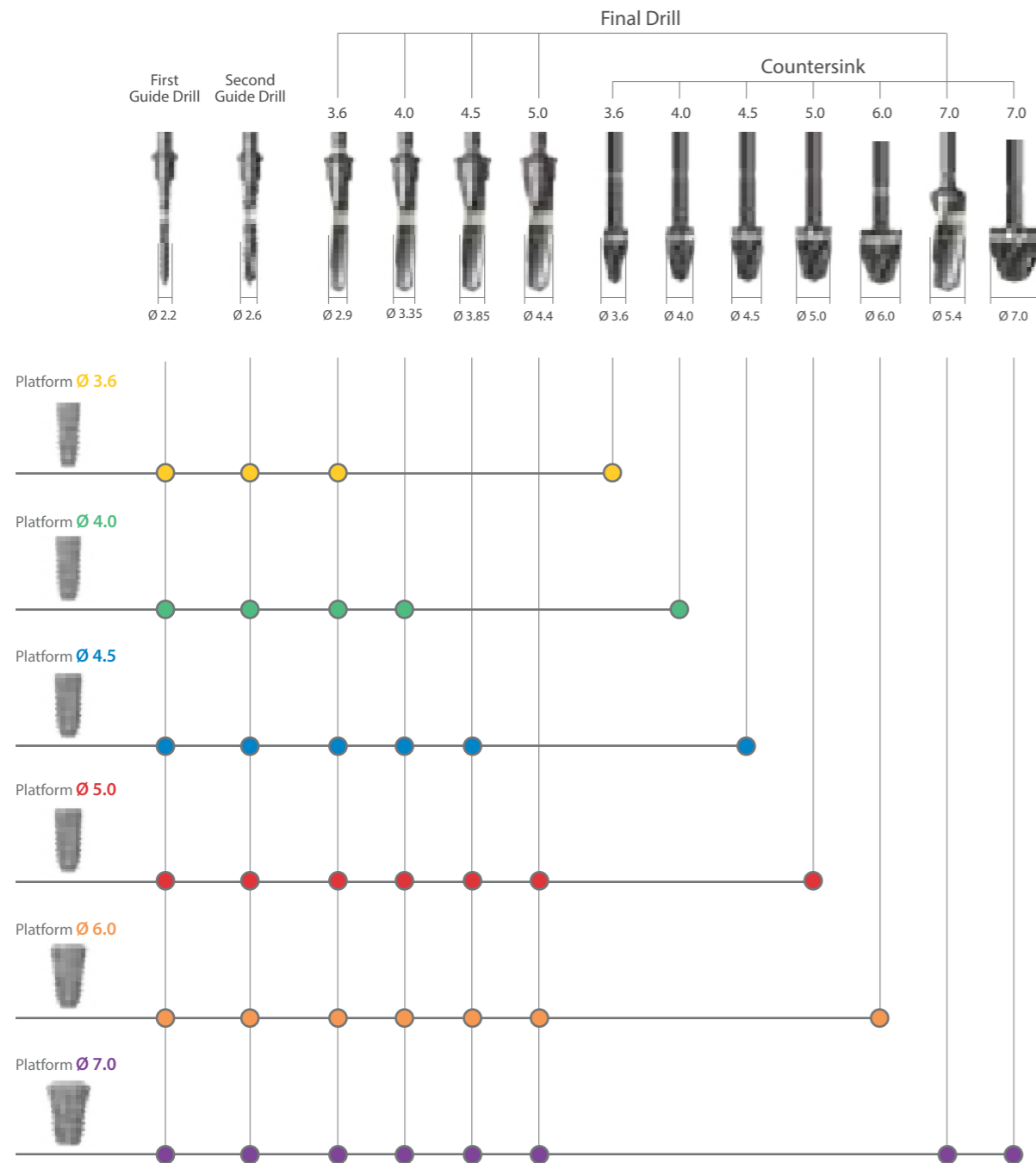

During Fixture Insertion, 70N-cm Torque at 50rpm is Recommended

- Countersink drill is used in cases with dense cortical bone.
- If the bone density is D1~D2, it is recommended to countersink after final drill.
- The actual diameter of the Countersink drill is 0.1mm larger than the fixture platform.

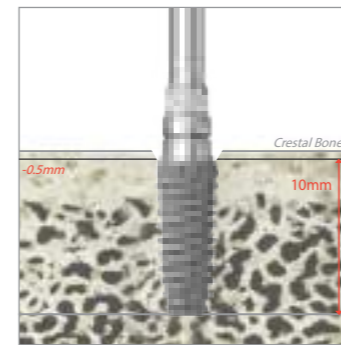
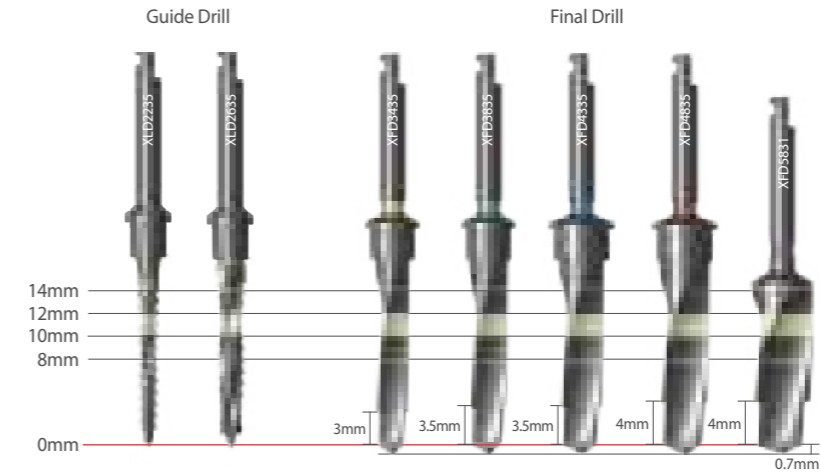

Determination of Fixture Top Level

Top level of fixture needs to be located 0.5mm below the marginal crestal bone level to minimize bone loss after implantation.

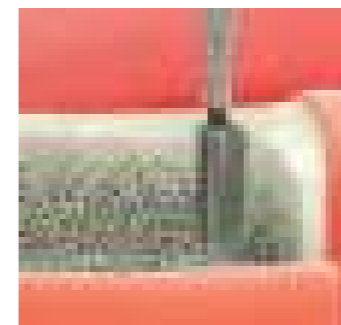

Depth Indication

- Use the depth gauge after first drill / First guide drill to check depth of drilling.
- Place the depth gauge against the wall of the osteotomy.

Surgical Drill Sequence II

Drilling Sequence Guide (Condensing Drill)

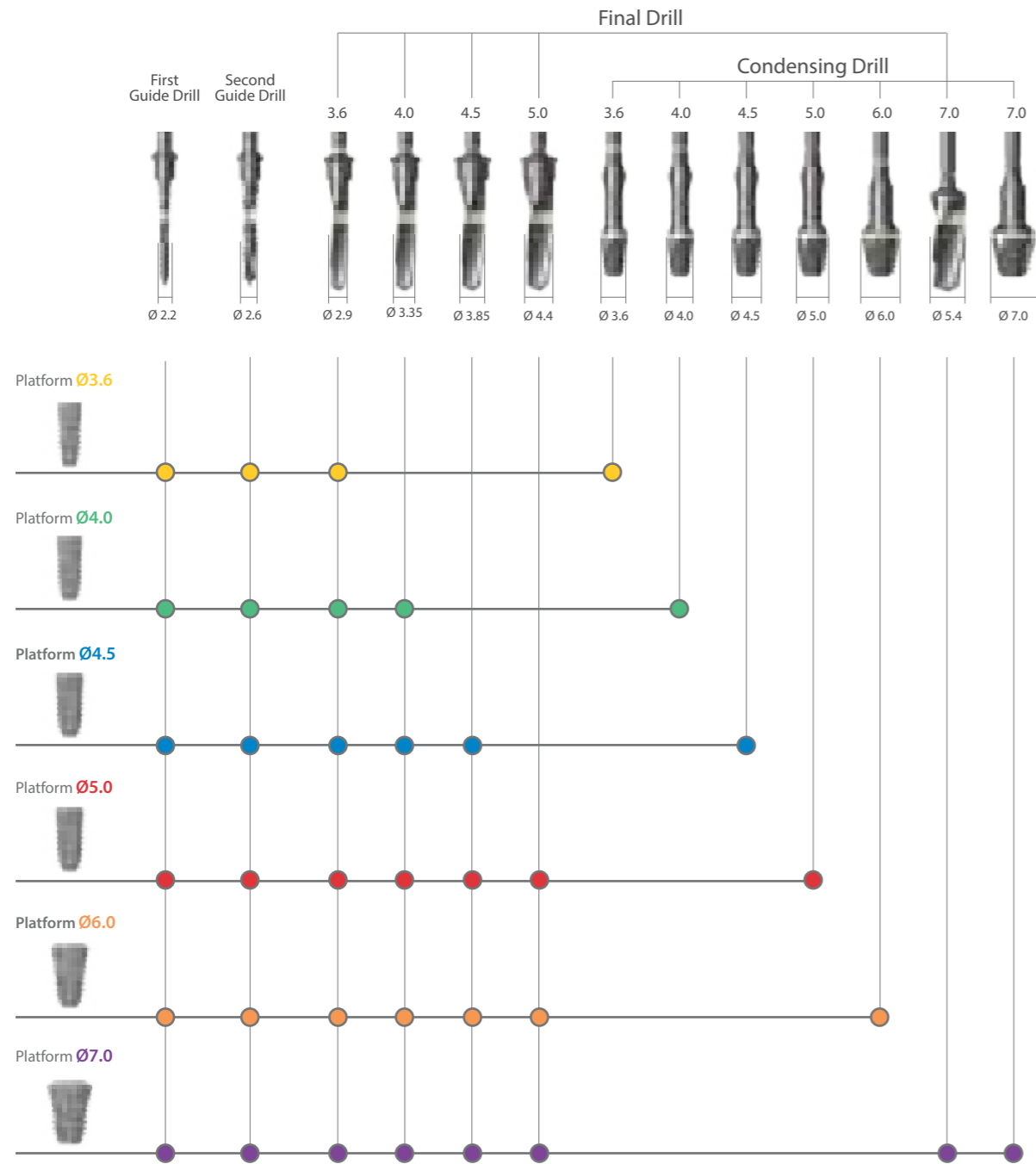

Condensing Drill

- Condensing Drill speed 20~60rpm, 30~45 N-cm with irrigation
- If the bone density is D1~D2, it is recommended to Condensing drill after final drill.
- The actual diameter of the Condensing drill is 0.1mm larger than the fixture platform.



Early loading with precise tap drill

- Tap drills for exquisite surgery to enable early loading.
- Smooth and precise surgery with tap drill in type 1~2 bone
- 4mm of tapping depth for optimum torque control.



Drilling Depth Guide

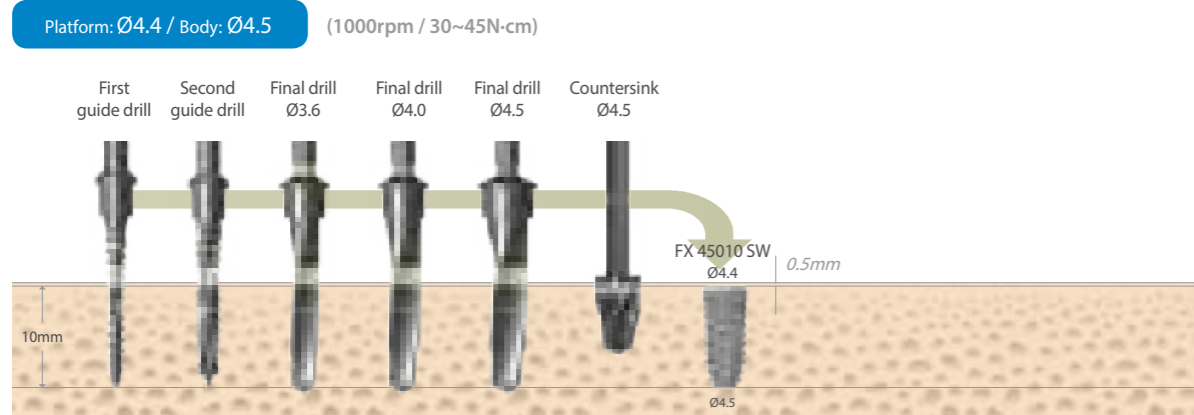
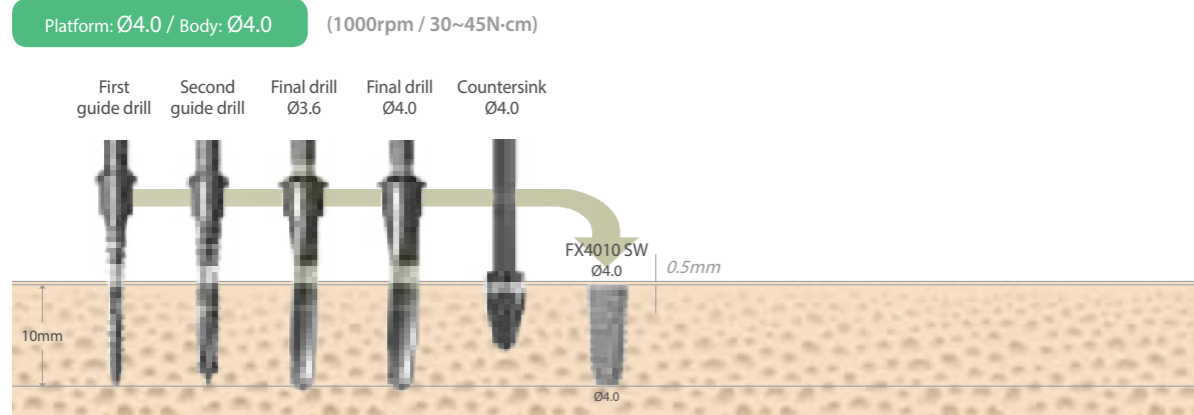
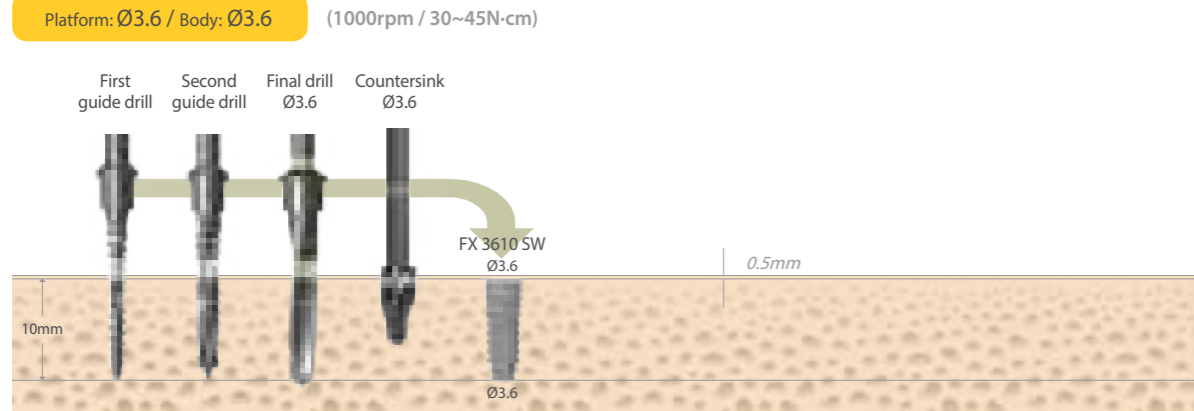

Drilling Depth Guide

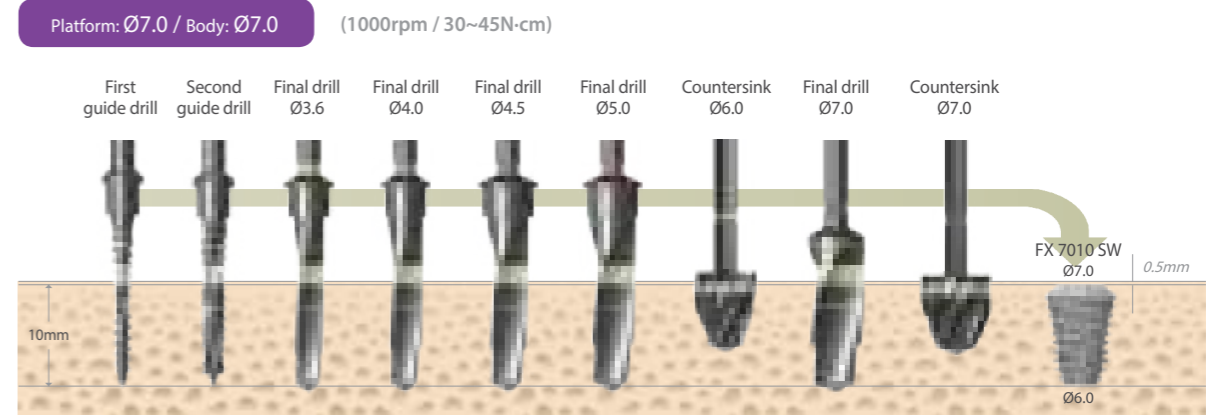
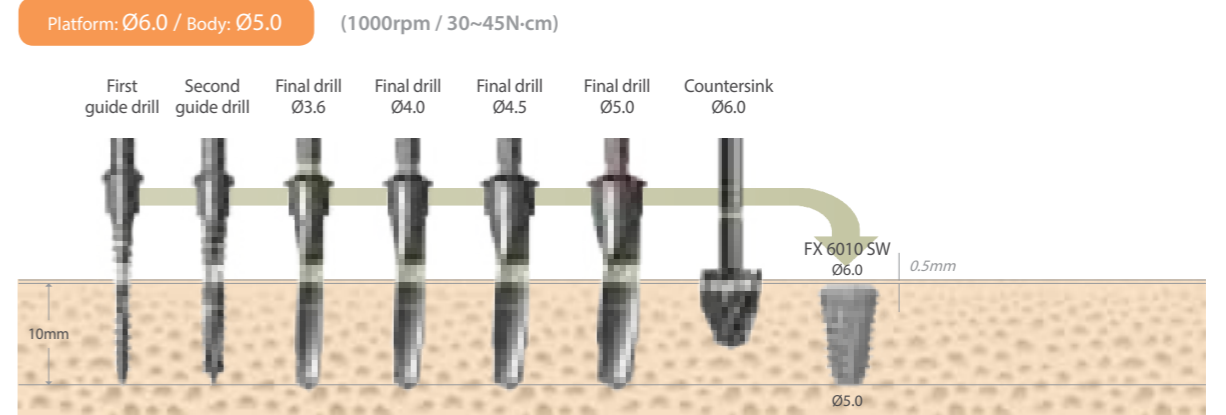
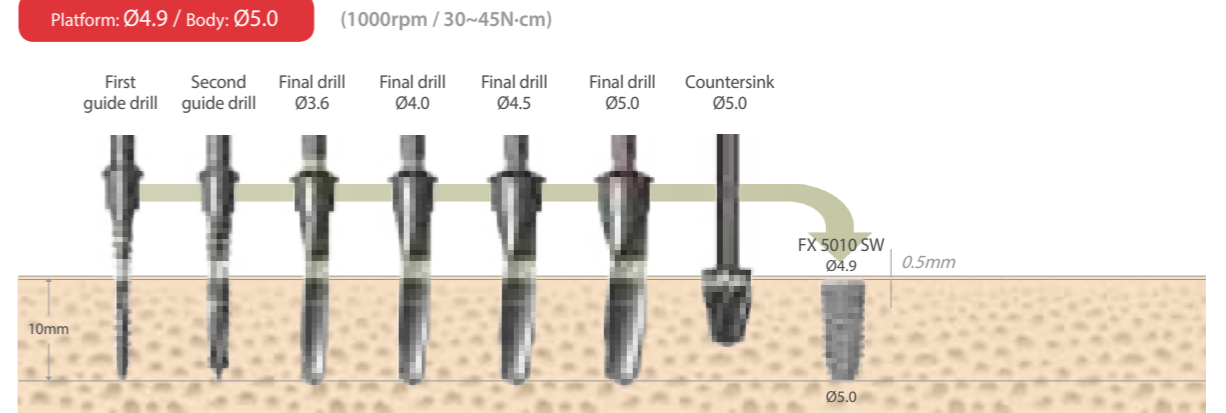

Fixture Connection

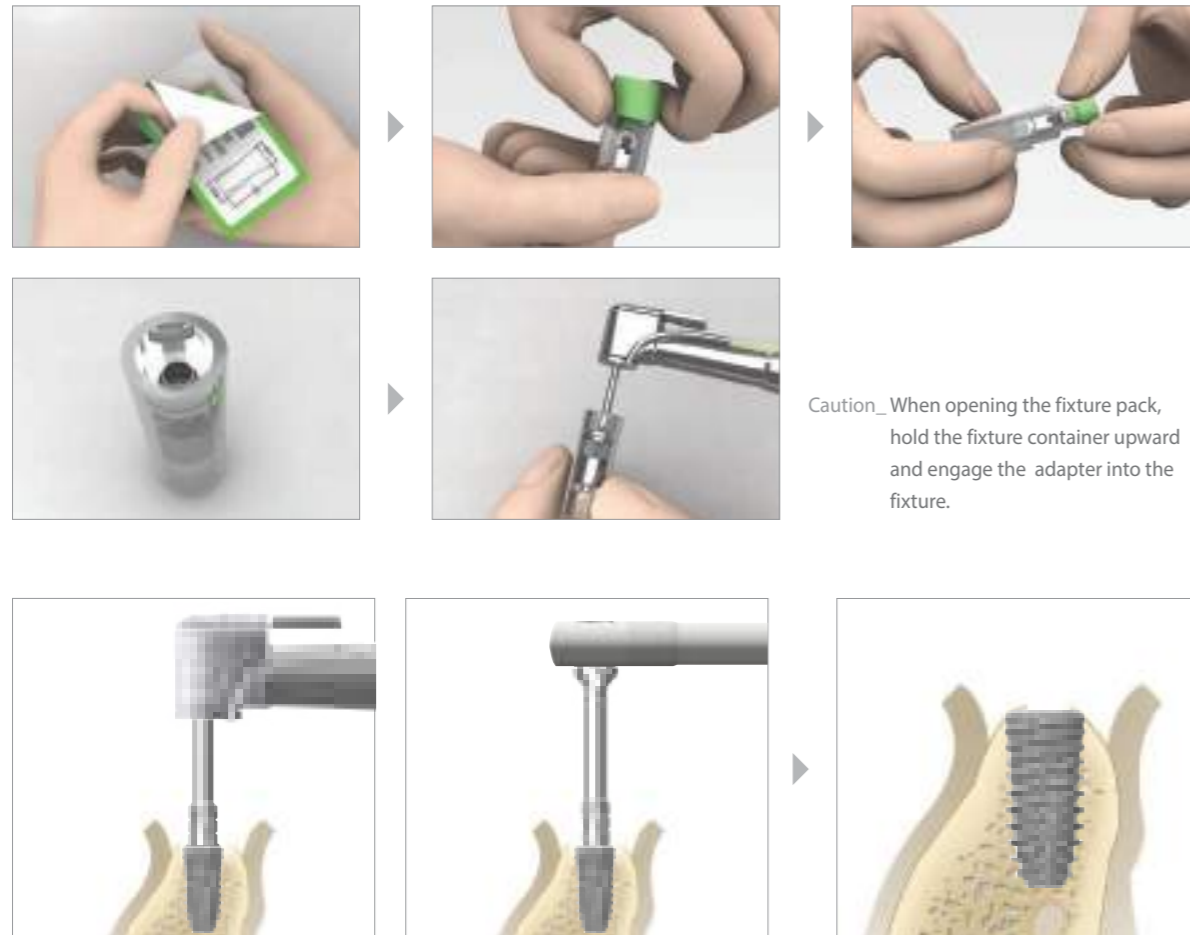

Caution_ When opening the fixture pack, hold the fixture container upward and engage the adapter into the fixture.

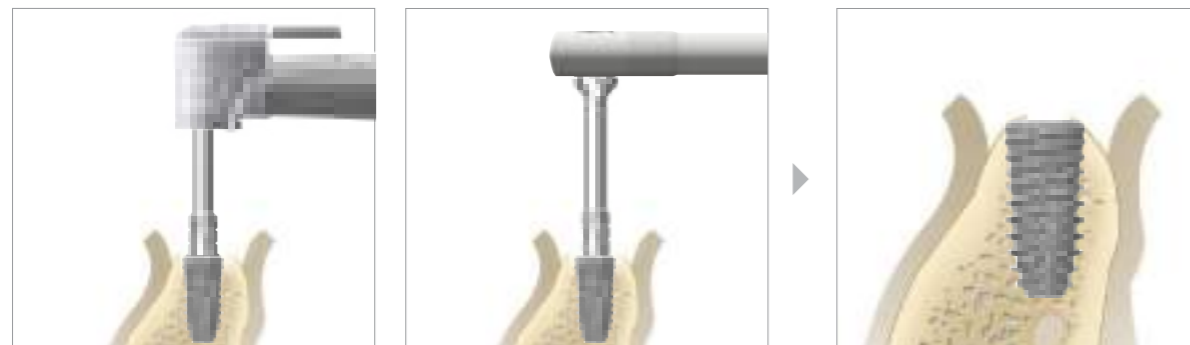

By hand-piece
20rpm / 35 N-cm

By ratchet

Directions Using the Hand-piece / Ratchet Adapter

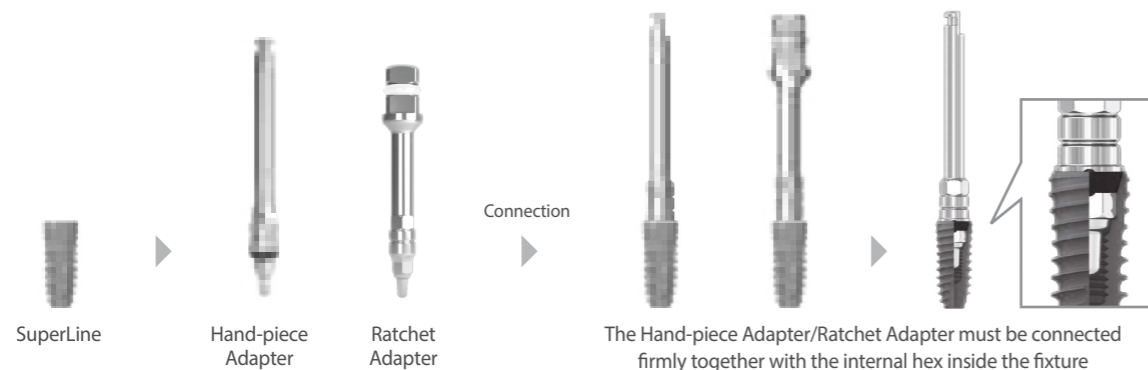

The Hand-piece Adapter/Ratchet Adapter must be connected firmly together with the internal hex inside the fixture

Installation Procedure & Warnings

Cover Screw

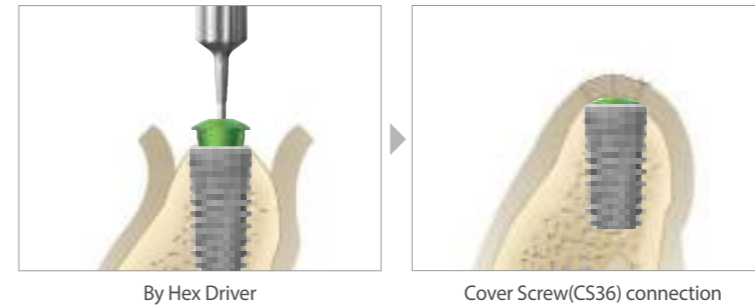

By Hex Driver

Cover Screw(CS36) connection

Healing Abutment



By Hex Driver

Healing Abutment connection

Healing Abutment (HAB402020L) connection in thin gingiva

Warnings

- Dental Implant surgery and restoration involve complex dental procedures. Appropriate and adequate training in proper technique is strongly recommended prior to use.
- Improper medical examination and/or treatment plan can result in implant failure and/or loss of supportive bone.
 - Improper initial stability and/or excessive occlusal forces during healing period may lead to osseointegration failure.
 - Excessive insertion torque may lead to mechanical failure or implant biologic failure due to bone compression and necrosis.
 - When forces or loads are greater than its design, implant or abutment fracture could happen. Therefore clinicians should make careful decisions with regards to clinical treatment planning to minimize the risk of fracture. Appropriate implant quantity, occlusal interface and a nightguard are essential. Potential excessive loading conditions may include the following:
 - 01 Inadequate number of implants are placed.
 - 02 Implant width and/or length are inappropriate for a treatment site.
 - 03 Prosthesis which has excessive cantilever length due to inadequate biomechanical design
 - 04 Continuous occlusal force are generated by incomplete connection between implant and abutment and/or abutment screw loosening.
 - 05 Direct Casting Abutment angles are greater than 30° from the vertical axis of the implant.
Direct Abutments are not for angulation.
 - 06 Occlusal interferences causing excessive lateral forces
 - 07 Patient parafunctions such as bruxism
 - 08 Inadequate dental laboratory casting procedures
 - 09 Improper prosthesis fit
 - 10 Trauma from patient habits or accidents
 - 11 Excessive marginal bone loss caused by inadequate bone width and/or advanced periimplantitis

Surgical Kit Maintenance

Manual Cleaning and Sterilization Procedure

It is important to use protective clothing and face shield while cleaning contaminated instruments. Always wear protective glasses, mask, gloves, etc. for your safety.

Cleaning

- 1 Rinse instruments immediately after use under running tap water (<40°C) for a minimum of one (1) minute to remove all debris including extraneous body fluids, bone debris and tissue.
- 2 Soak all instruments immediately after rinsing in an enzymatic cleaning solution* for 10 to 20 minutes (Do not soak overnight).
 - * Follow manufacturer's instructions and observe recommended cleaning solution concentrations (enzymatic detergent with a pH level between 7-10 and temperature not to exceed 40°C). Do not use incompatible cleaning solutions to clean instruments.
- 3 For internal irrigation drills, use a 1mL syringe and a 25 gauge needle to clean the drill irrigation hole with a minimum of 0.2 mL of the prepared cleaning solution. Repeat this step two (2) more times for a total of three (3) rinses.
- 4 Scrub with a soft brush for a minimum of 1 (one) minute to remove any debris inside the drill irrigation hole.
- 5 Rinse the instruments under running tap water (<40°C) for a minimum of 1 minute. Use a 1mL syringe and a 25 gauge needle with a minimum of 0.2 mL of tap water to forcefully flush inside the drill irrigation hole. Repeat flushing of drill irrigation hole two (2) more times for a total of three (3) flushings.
- 6 Place instruments into an ultrasonic cleaner with neutral detergent**. Keep instruments inside the ultrasonic bath for 15 minutes using a frequency of 25-50 kHz. Ensure multiple instruments placed within the bath remain separated.
 - ** Follow manufacturer's instructions and observe recommended neutral detergent solution concentrations (neutral detergent with a pH level between 7-10 and temperature not to exceed 40°C). Do not use incompatible neutral detergent solutions to clean instruments.
- 7 Rinse instruments thoroughly with running tap water (<40°C) for a minimum of 1 (one) minute until all traces of neutral detergent solution are removed. Rinse inside drill irrigation hole using a 1mL syringe and a 25 gauge needle with a minimum of 0.2 mL of tap water. Repeat rinsing drill irrigation hole two (2) more times for a total of three (3) rinses.
- 8 Gently wipe instruments with a soft lint-free cloth or place the instruments in a drying cabinet (60°C for less than 10 hours) until fully dry. Blow residual water from drill irrigation hole using a 1mL syringe and a 25 gauge needle. Visually inspect instruments in a well-lit area to ensure they are clean, dry and free of residue.
- 9 Clean instrument trays with a germicidal cleaner prior to returning instruments into Kit.
- 10 Always check for damage or corrosion after rinsing and drying.

Sterilization

Dentium recommends either the Pre-vacuum or Gravity autoclave methods for sterilization under the conditions described below. However, autoclave performance can affect the efficacy of this process. Healthcare facilities should validate their sterilization processes employing the actual equipment and operators that routinely sterilize instruments.

All autoclaves/sterilizers should be regularly validated, maintained and checked in accordance with EN 285/EN 13060, EN ISO 17665, ANSI AAMI ST79 to ensure compliance with these and related standards. Make sure packaging is suitable for steam sterilization.

Recommended Sterilization Parameters

Method-Moist Heat Sterilization	Pre-vacuum	Gravity
Set Point Temperature	132 °C	132 °C
Exposure time	4 minutes	30 minutes
Drying time	20 minutes	40 minutes

PROSTHESIS MANUAL

Understanding the Implant and Prosthesis

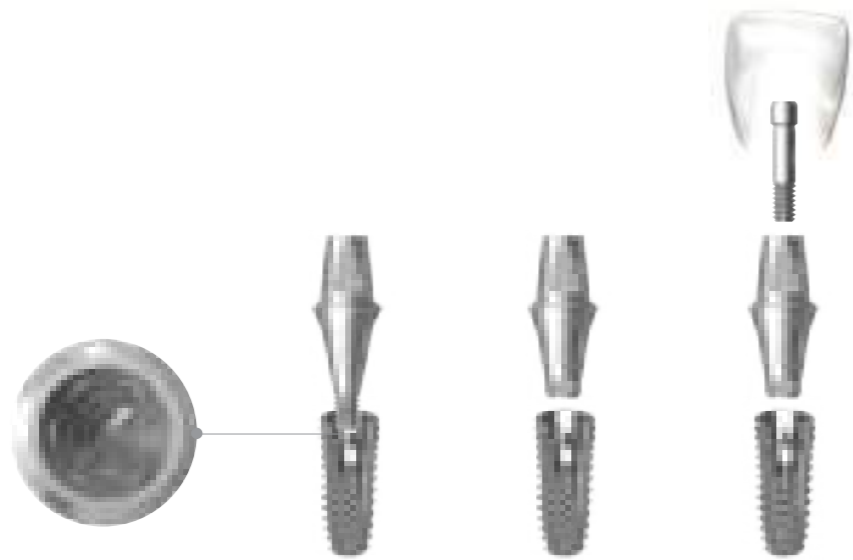

Biological Connection











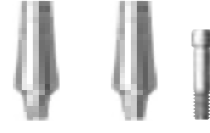

- The tapered conical hex connection between implant and abutment interface provides hermetic sealing.
- The biological connection distributes the load to the fixture evenly. Therefore it may minimize bone loss.
- All implant diameters share the same internal connection. One abutment screw fits all abutments and fixtures.

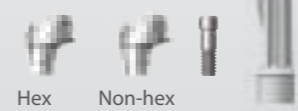

Types of Abutment (Abutments are available in various diameters & gingival heights)

- | | | |
|---|-----|---------------------------------|
| · Dual Abutment | [] | Abutment level |
| · Combi Abutment | | |
| · Dual Abutment | [] | Fixture level |
| · Dual Milling Abutment | | |
| · Angled Abutment (15°/25°) | | |
| · Direct-Casting Abutment | | |
| · Metal-Casting Abutment | | |
| · Temporary Abutment (Plastic & Titanium) | | |
| · Screw Abutment | [] | Screw retained (Abutment level) |
| · Angled Screw Abutment (15°/ 30°) | | |
| · Positioner Attachment | [] | For denture use |
| · Ball Attachment | | |
| · Magnetic Attachment | | |

Types of Abutment

One-Piece	Two-Pieces	
 Combi Abutment	 Hex Non-hex Dual Abutment	 Hex Non-hex Milling Abutment
 Screw Abutment	 Hex Non-hex (15°) Angled Abutment	 Custom Abutment
 Hex Non-hex (20°) Angled Screw Abutment	 Hex Non-hex (25°) Angled Abutment	 Hex Non-hex Direct-Casting Abutment
 Cylinder	 Hex Non-hex Metal-Casting Abutment	 Titanium Plastic Hex Non-hex Hex Non-hex Temporary Abutment
Abutment Level	Fixture Level	

- Straight abutments are Dual and Combi Abutment.
- Depending on the insertion angle and position of the fixture, the Angled or Direct / Metal - Casting Abutment may be used.
- The Screw Abutment can be used when prosthesis retrieval is anticipated.

Dual Abutment

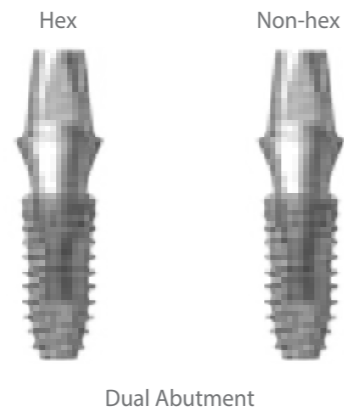

Dual Abutment

- It is possible to take an impression at both fixture level and abutment level. (A Dual Abutment may be interchangeable with a Combi Abutment)
- For abutment level impressions, the same prosthetic procedures apply to both Dual and Combi Abutments.
- For fixture level impressions, the abutment selection takes place on the master model.
- For fixture level impressions, a precise positioning jig for abutment may be required.
- Either hex or non-hex abutments may be used, according to operator's preference.

* If a cement retained restoration requires retrieval, cutting a hole in the occlusal surface would allow access to the screw to permit removal.

Hex / Non-hex

	Hex	Non-hex
Positioning Jig	Unnecessary	Required
Radiograph	Unnecessary	Unnecessary

Dual Abutment Line Up (Hex / Non-hex)

Diameter	G/H	Vertical Angle
Ø4.5	1.0mm, 1.5mm, 2.5mm, 3.5mm, 4.5mm, 5.5mm	5°
Ø5.5	1.5mm, 2.5mm, 3.5mm, 4.5mm, 5.5mm	6°
Ø6.5	1.5mm, 2.5mm, 3.5mm, 4.5mm, 5.5mm	7°



Combi Abutment

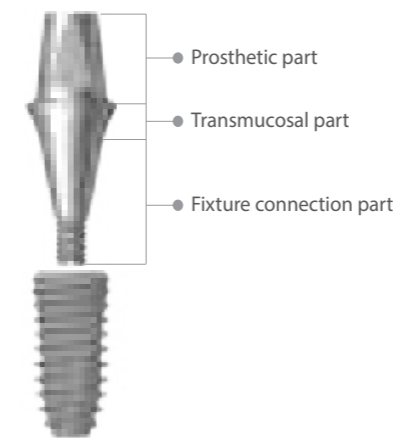

Combi Abutment

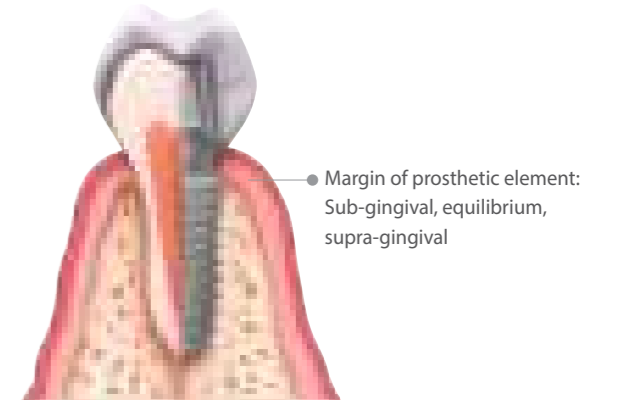

- The Combi Abutment is used when the implant position is optimal.
- If the abutment selection is made in the mouth, gauge the thickness of mucosa with the depth gauge to measure the gingival height thus allowing the appropriate abutment height.
- The Impression is taken with the snap cap.
- When using the Combi Abutment, it remains in the mouth after the impression is taken. (Do not remove or change its position)
- Tighten abutment screw to 25 - 35 N·cm. (retighten again before seating final prosthesis).

* If the Combi Abutment is too long it can be adjusted 1.5mm to the bottom of the laser mark on the vertical stack of the abutment. The Combi Abutment has a short analog for the 1.5mm adjustment.

* A resin jig can be made to record the reduction if reduced more the 1.5mm.

Combi Abutment Line Up

Diameter	G/H	Vertical Angle
Ø4.5	1.0mm, 1.5mm, 2.5mm, 3.5mm, 4.5mm, 5.5mm	5°
Ø5.5	1.5mm, 2.5mm, 3.5mm, 4.5mm, 5.5mm	6°
Ø6.5	1.5mm, 2.5mm, 3.5mm, 4.5mm, 5.5mm	7°



Custom / Milling Abutment

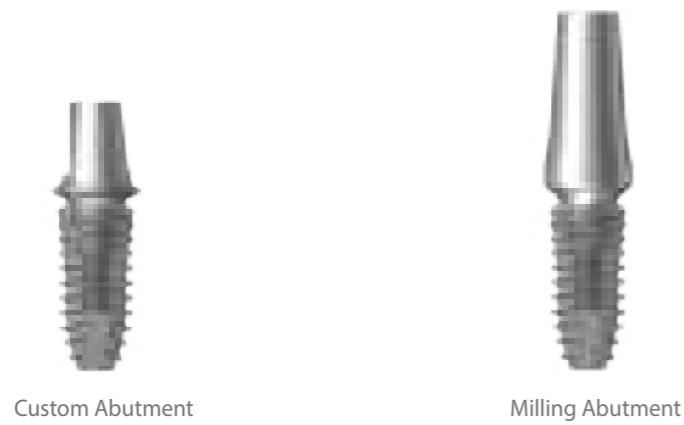

Custom Abutment

- Impression is taken at fixture level.
- When using a non-hex abutment a precise seating jig should be used.

Diameter	G/H	Type
Ø4.5	0.5mm, 1.5mm	Hex / Non-hex
Ø5.5	1.0mm, 2.0mm	

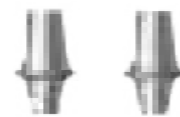

Milling Abutment

- Impression is taken at fixture level.
- When using a non-hex abutment a precise seating jig should be used.
- Either hex or non-hex abutments may be used, according to operators preference.

* If a cement retained restoration requires retrieval, cutting a hole in the occlusal surface would allow access to the screw for removal.

Diameter	G/H	Type
Ø4.0	1.0mm	Hex / Non-hex
Ø4.5	1.5mm	
Ø5.5	1.5mm, 2.5mm	
Ø6.5	1.5mm, 2.5mm, 3.5mm	
Ø7.5	2.5mm, 3.5mm	

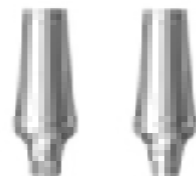

Angled Abutment

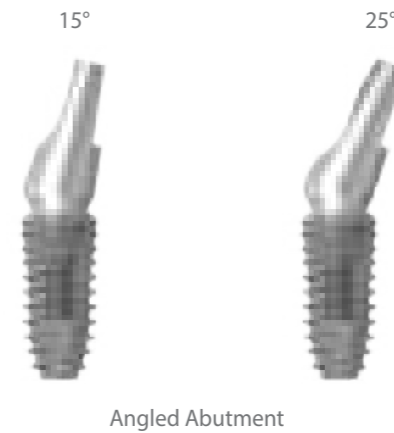

- The Angled Abutment is recommended when the restoration path of insertion is unfavorable in either anterior or posterior sites.
- Retention force can be increased through milling process.

Angled Abutment Line Up

Diameter	G/H	Angle
Ø4.5	1.5mm 2.5mm 3.5mm	15° / 25°
Ø5.5	1.5mm 2.5mm 3.5mm	



Direct-Casting / Metal-Casting Abutment



Direct-Casting Abutment



Metal-Casting Abutment

Direct-Casting Abutment

- Excellent for either single or bridgework
- Used as an esthetic custom made abutment.
- Used when angulation is not ideal and a standard abutment cannot be used.
- Used when there is inadequate inter-arch distance and a standard abutment cannot be used.
- A fixture level impression is taken, and the soft tissue contours can be supported.

Diameter	G/H	Type
Ø4.5	1.0mm	Hex / Non-hex



Metal-Casting Abutment

- Equivalent results for a fraction of the price
- Our highly affordable metal alloy replaces expensive gold to alleviate financial burden to all.

Diameter	G/H	Type
Ø4.5	1.0mm	Hex / Non-hex

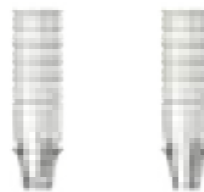

Temporary Abutment



Ti-Temporary Abutment



Plastic Temporary Abutment

Temporary Abutment

- Temporary Abutments are available with titanium or plastic.
- The titanium abutment comes in both hex and non-hex with a gingival height of 1.0mm.
- The plastic abutment comes in diameters (Ø4.5, 5.5, 6.5) with a gingival height of 2.0mm.

Abutment	Diameter	G/H	Type
Ti-Temporary	Ø4.5	1.0mm	Hex / Non-hex
Plastic Temporary	Ø4.5	2.0mm	Hex / Non-hex
	Ø6.5		

Screw Abutment



Screw Abutment



Angled Screw Abutment

If prosthesis repair is anticipated, use of a Screw Abutment retained prosthesis enables easy retrieval.

- Useful for connecting multiple units or when there is a preference for a screw retained prosthesis.
- Useful when respective long axes of implants differ. Each side tapers by 30° and this permits up to 60° divergence between two abutments.
- Useful when the prognosis of an adjacent restoration is not ideal thus permitting easy retrieval and modification of the restoration.

Ti-Retaining Screw (1.8mm - body diameter)

- Can minimize screw loosening due to increased approximal space.
- Can endure various kinds of masticatory force.

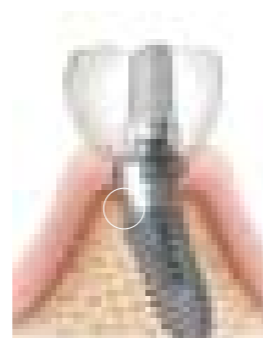
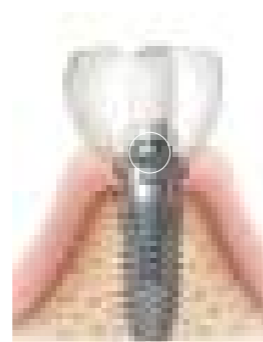
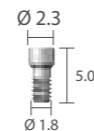

Screw Abutment Line Up

Diameter	G/H
Ø4.5	1.0mm, 1.5mm, 2.5mm, 3.5mm, 4.5mm, 5.5mm
Ø5.5	1.5mm, 2.5mm, 3.5mm, 4.5mm, 5.5mm

Angled Screw Abutment Line Up

Diameter	G/H	Angle
Ø4.5	1.0mm 2.0mm 3.0mm	20°
Ø5.5	1.0mm 2.0mm 3.0mm	

Points to Consider in Abutment Selection

Considerations in Selecting an Abutment

- Esthetic requirement
- Implant angulation
- Implant location
- Fixture installation depth (Gingival height)
- Interarch distance
- Prosthesis type
- Dentist & dental technician's preference

Impression of Implant

According to the case the impression can be taken at abutment or fixture level.

Fixture Level	Abutment Level
1. Dual Abutment	1. Dual Abutment
2. Dual Milling Abutment	2. Combi Abutment
3. Angled Abutment (15° / 25°)	3. Screw Abutment
4. Direct-Casting Abutment	4. Angled Screw Abutment (20°)
5. Metal-Casting Abutment	
6. Temporary Abutment (Plastic & Titanium)	

Abutment Impression Recommendation

Abutment	Type	Impression
Dual Abutment	Cementation type, screw-cementation type	Fixture level impression or abutment level impression
Combi Abutment	Cementation type	Abutment level impression
Angled Abutment	Cementation type, screw-cementation type	Fixture level impression
Screw Abutment	Screw retained type	Abutment level impression
Direct-Casting Abutment	Cementation type, screw-cementation type	Fixture level impression
Metal-Casting Abutment	Cementation type, screw-cementation type	Fixture level impression
Dual Milling Abutment	Cementation type, screw-cementation type	Fixture level impression

Minimum Height Requirement for SuperLine Prosthetic Abutment

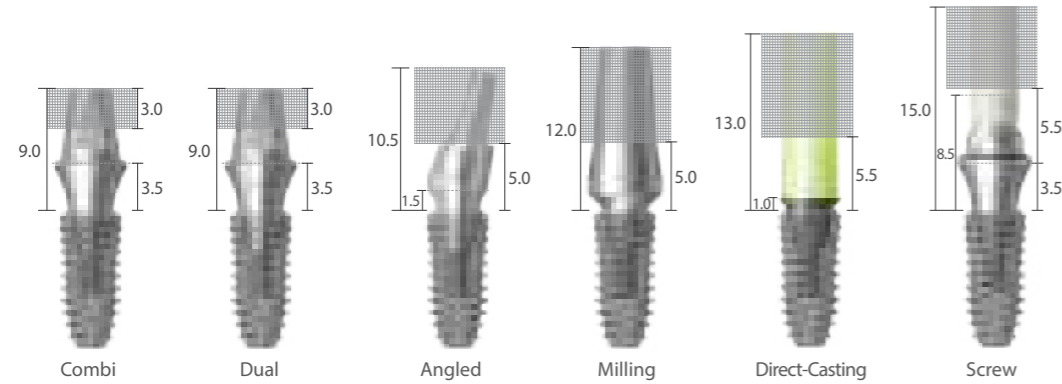

* Diagram above indicates the minimum height required for SuperLine prosthetic abutment.

Maximum Amount of Reduction Allotted for SuperLine

Combi Abutment

- Eliminate 3.0mm from the top level Combi Abutment (laser marking:1.5mm)
- Caution _ Damage may be caused to the screw if the abutment is reduced to less than 2.5mm above the gingival height.

Dual Abutment

- Preparation of the abutment top is possible as follows.

Gingival Height	Preparable Amount
1.5mm	2.0
2.5mm	3.0
3.5mm	4.0
4.5mm	5.0
5.5mm	6.0

Angled Abutment & Milling Abutment

- Preparation of the abutment top is possible as follows.

Direct-Casting Abutment & Metal-Casting Abutment

- Required minimum abutment height: at least 5.5mm above the Fixture top.

Direct-Casting Abutment & Metal-Casting Abutment

- The Screw Abutment cannot be modified, however the Casting Abutment can be modified for interarch distance, taking reduction into consideration of the height of the retaining screw.

Prosthetic Procedure 1

Impression Technique and Restoration Selection

Dual / Combi Abutment

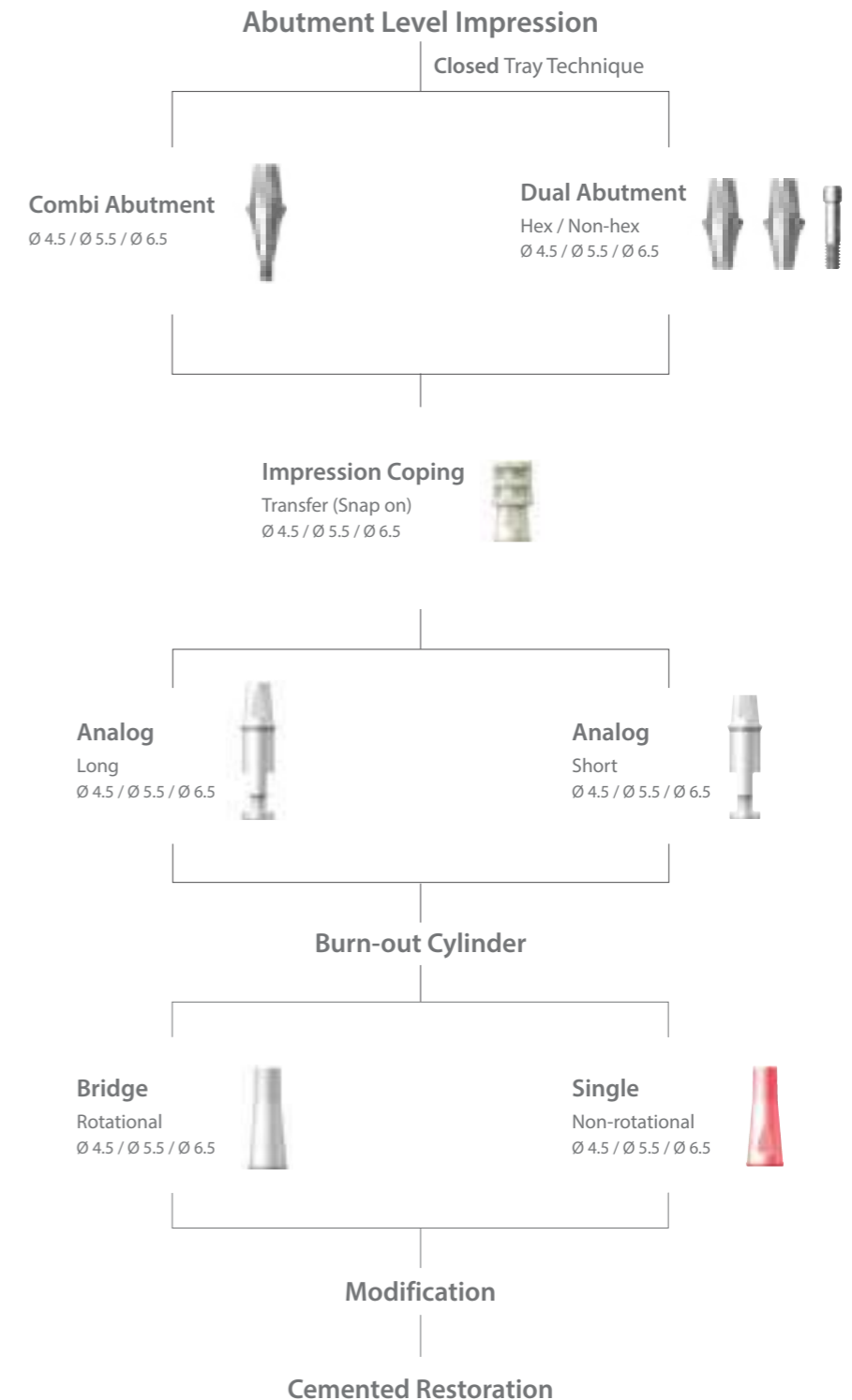

Abutment Level_Dual Abutment

[Multiple Units]

Clinical Procedure

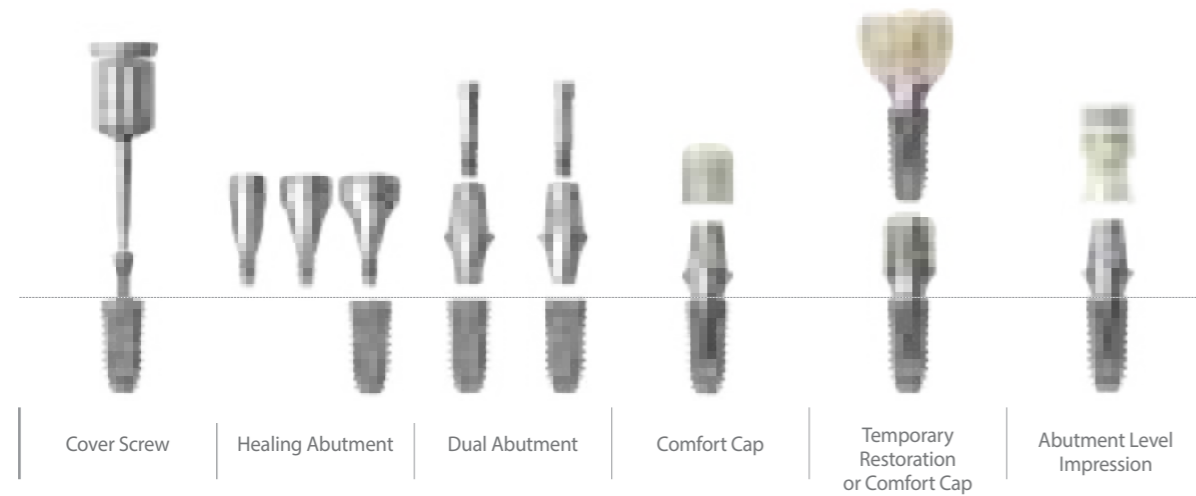

Chairside

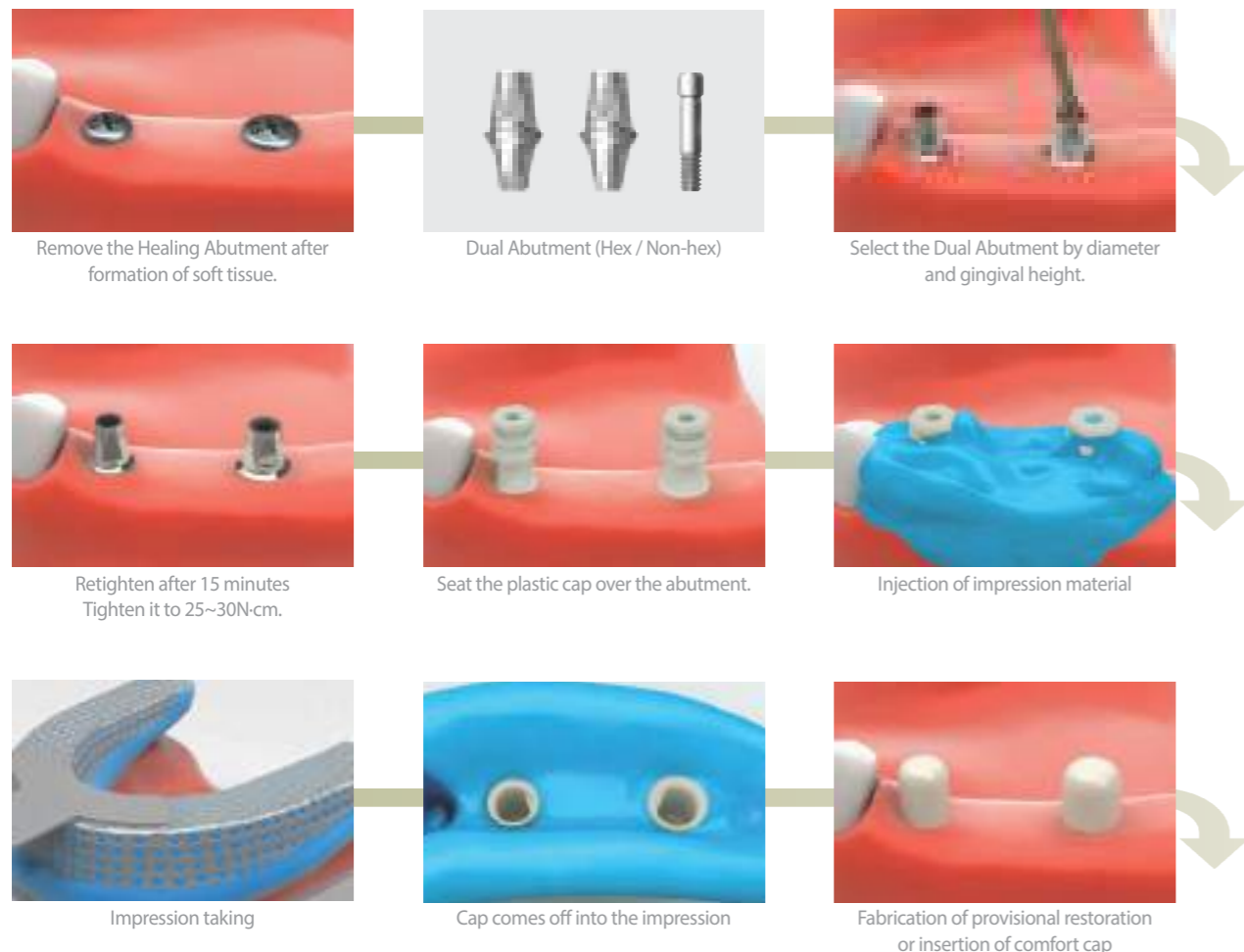

Abutment Level_Dual Abutment

[Multiple Units]

Clinical Procedure

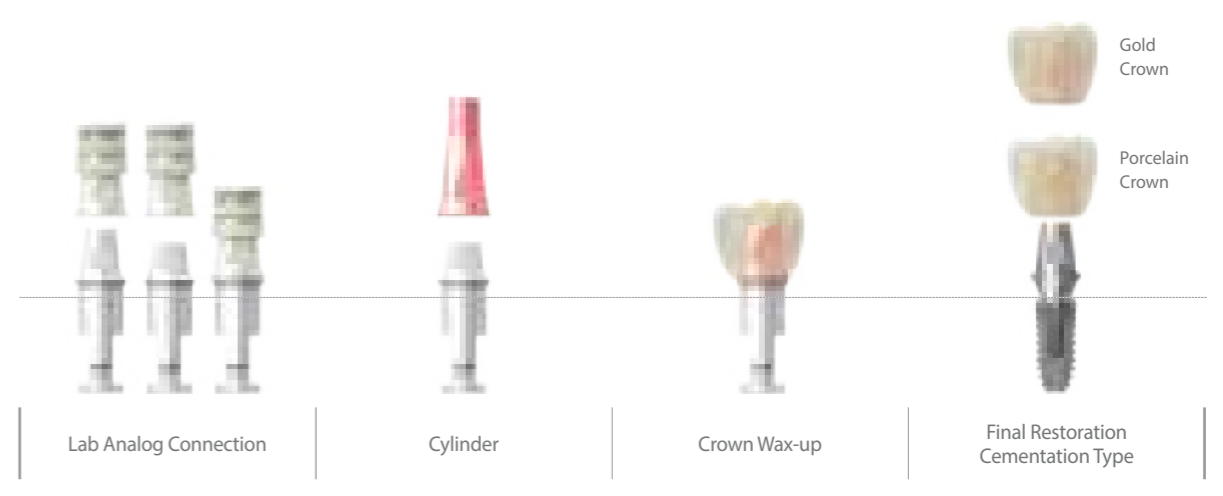

LabSide

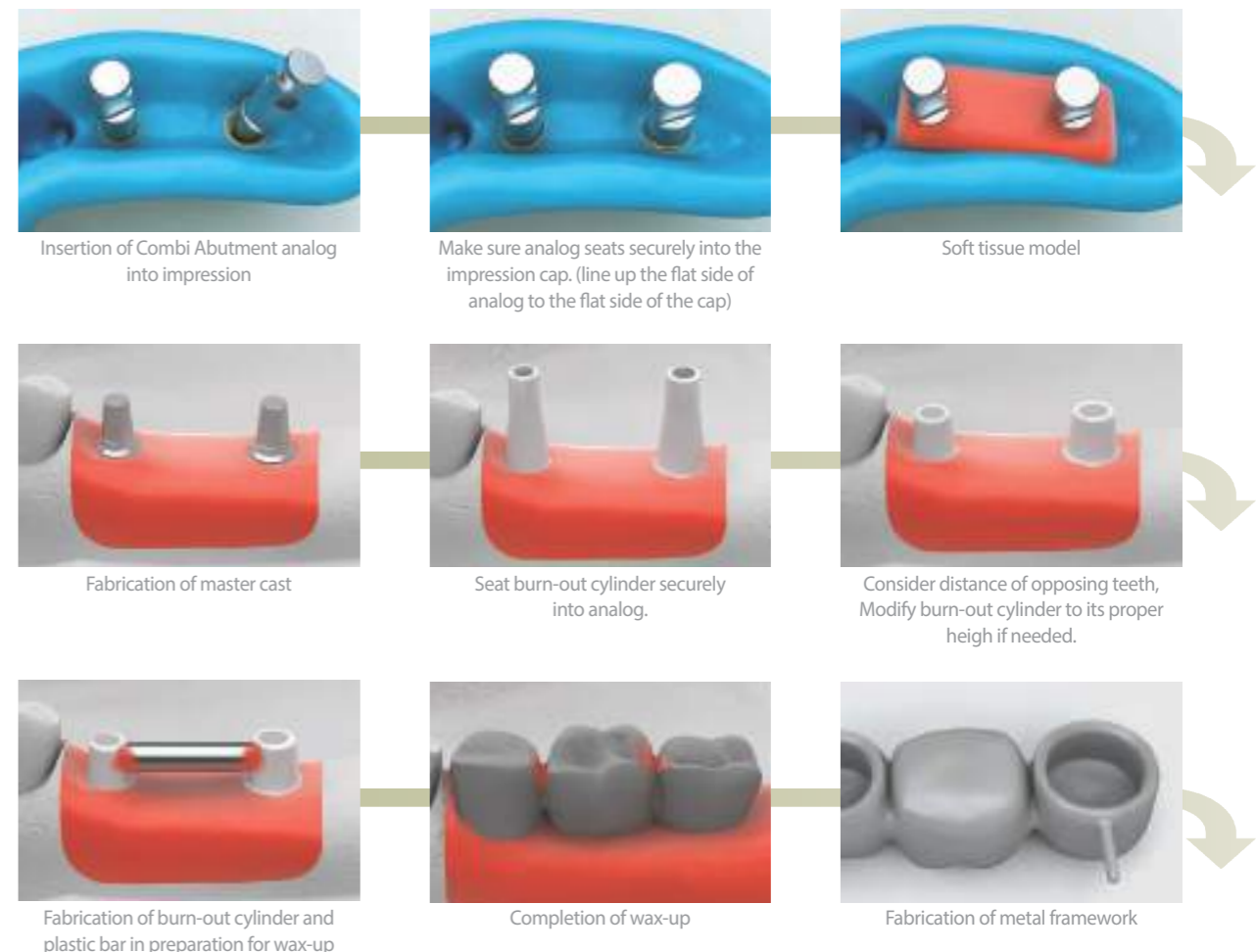

Abutment Level_Dual Abutment

[Multiple Units]



Metal framework after removal of "Lip"

Metal framework

Porcelain build-up

SCRIP: Once an access hole has been created, it can be converted to a SCRIP (Screw & Cemented Retained Prosthesis).



Final prosthesis

Access hole is made when burn-out cylinder is used to do the wax-up.

Extended margin around the metal framework due to 'snap-on' mechanism



Trim extended margin by rubber wheel

Metal framework and reamer

Eliminate the lip remnant caused by 'snap-on' mechanism by reamer.



Metal framework after removal of "Lip"

Metal framework

Final prosthesis

Abutment Level_Combi Abutment

[Multiple Units]

Chairside



Second stage surgery (uncovering)

Following the 2nd stage surgery, soft tissue is healed around the Healing Abutment. Healing Abutment should be selected according to the size of abutment.

Choose abutment with gingival height then tighten it to 25-30N-cm. Re tighten after 15 minutes.



Image of combi Impression coping and abutment assembly

Snap-on the plastic impression coping with the same sized diameter abutment

Impression taking Injection of impression material



Impression taking

Inner-surface of impression

Extended margin around the metal framework due to 'snap-on' mechanism

Chairside



Seating of Lab analog

Confirm analog is secured in snap cap

Soft tissue model



Fabrication of master cast

Placement of burn-out cylinder

Consider the distance of opposing teeth, modify burn-out cylinders to its proper height.

Abutment Level_Combi Abutment

[Multiple Units]

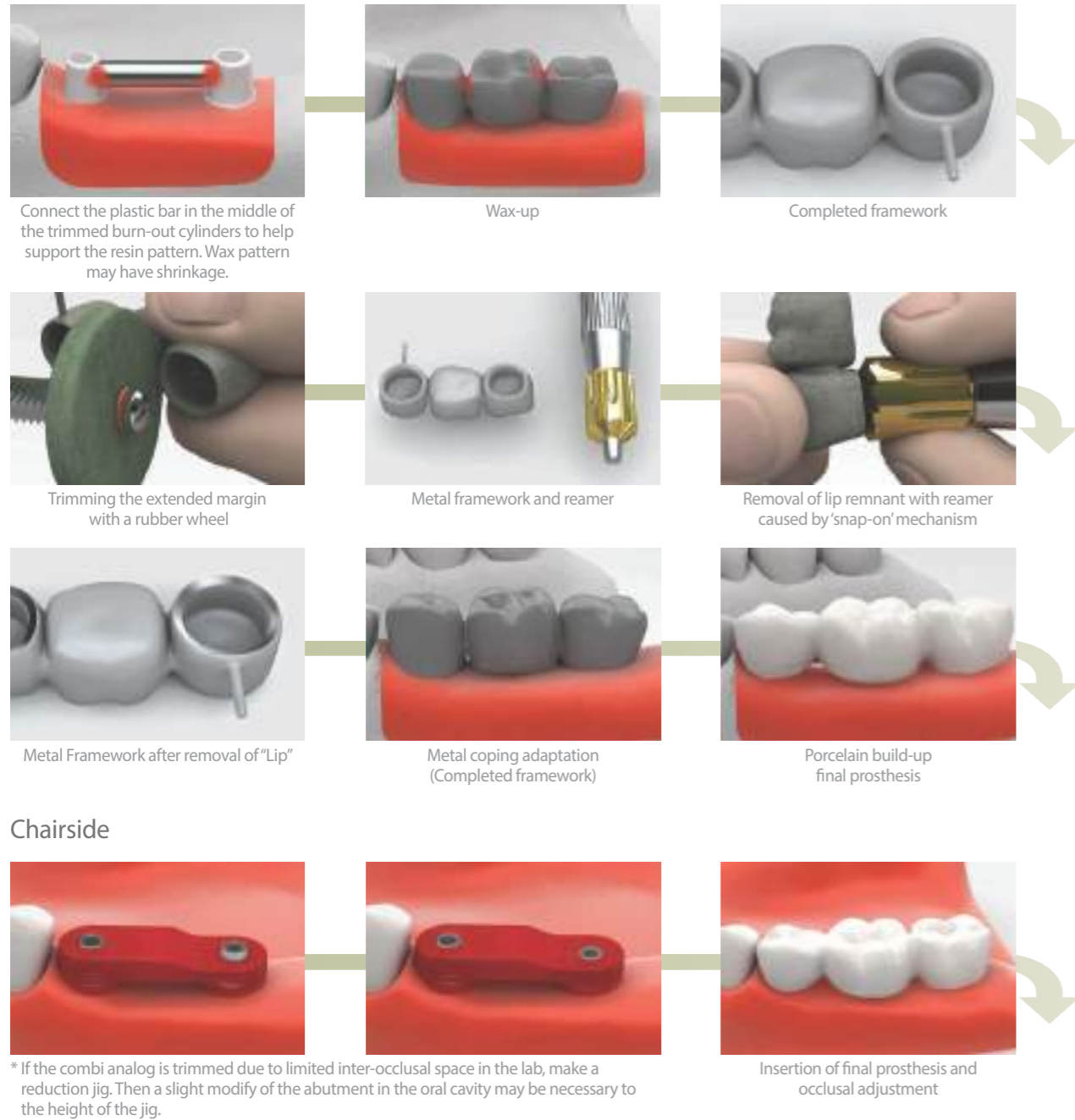

* If the combi analog is trimmed due to limited inter-occlusal space in the lab, make a reduction jig. Then a slight modify of the abutment in the oral cavity may be necessary to the height of the jig.

Prosthetic Procedure 2

Impression Technique and Restoration Selection

Dual / Custom / Milling / Angled / Direct-Casting / Metal-Casting / Ti-Temporary / Plastic Temporary Abutment

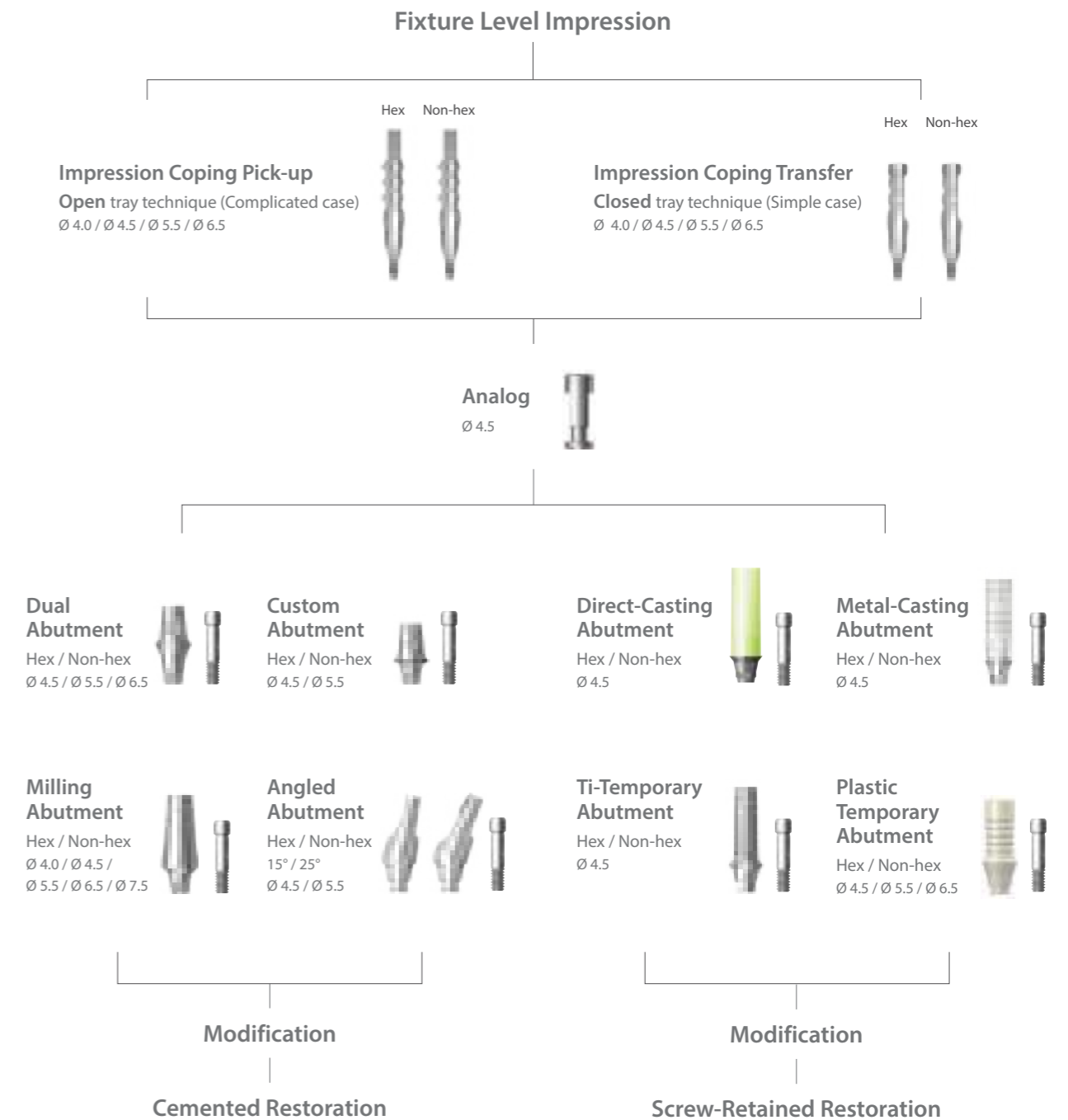

Fixture Level [Pick-up Type]_Dual Abutment

[Multiple Units]

Clinical Procedure



LabSide

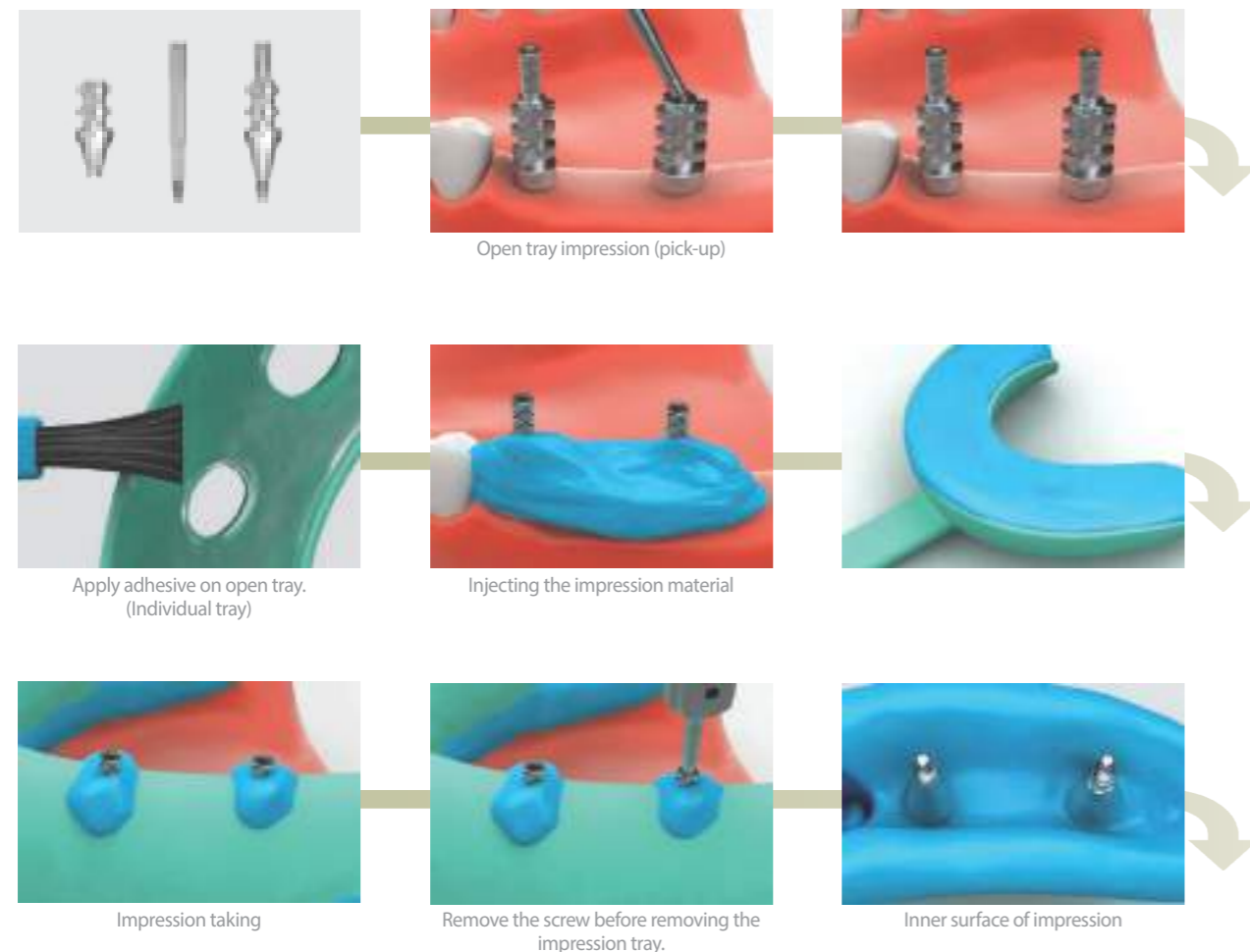

Fixture Level [Pick-up Type]_Dual Abutment

[Multiple Units]

Clinical Procedure

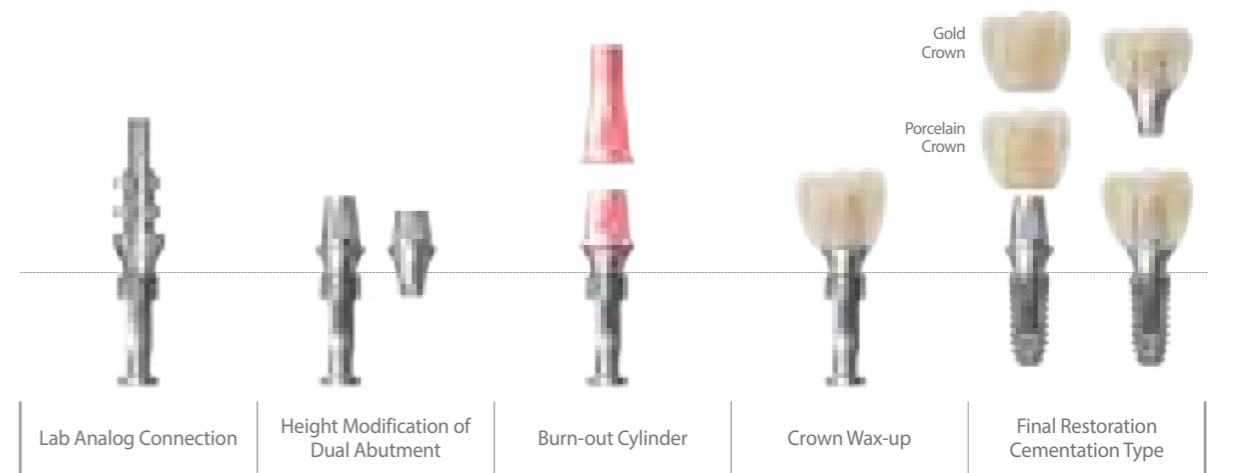

LabSide

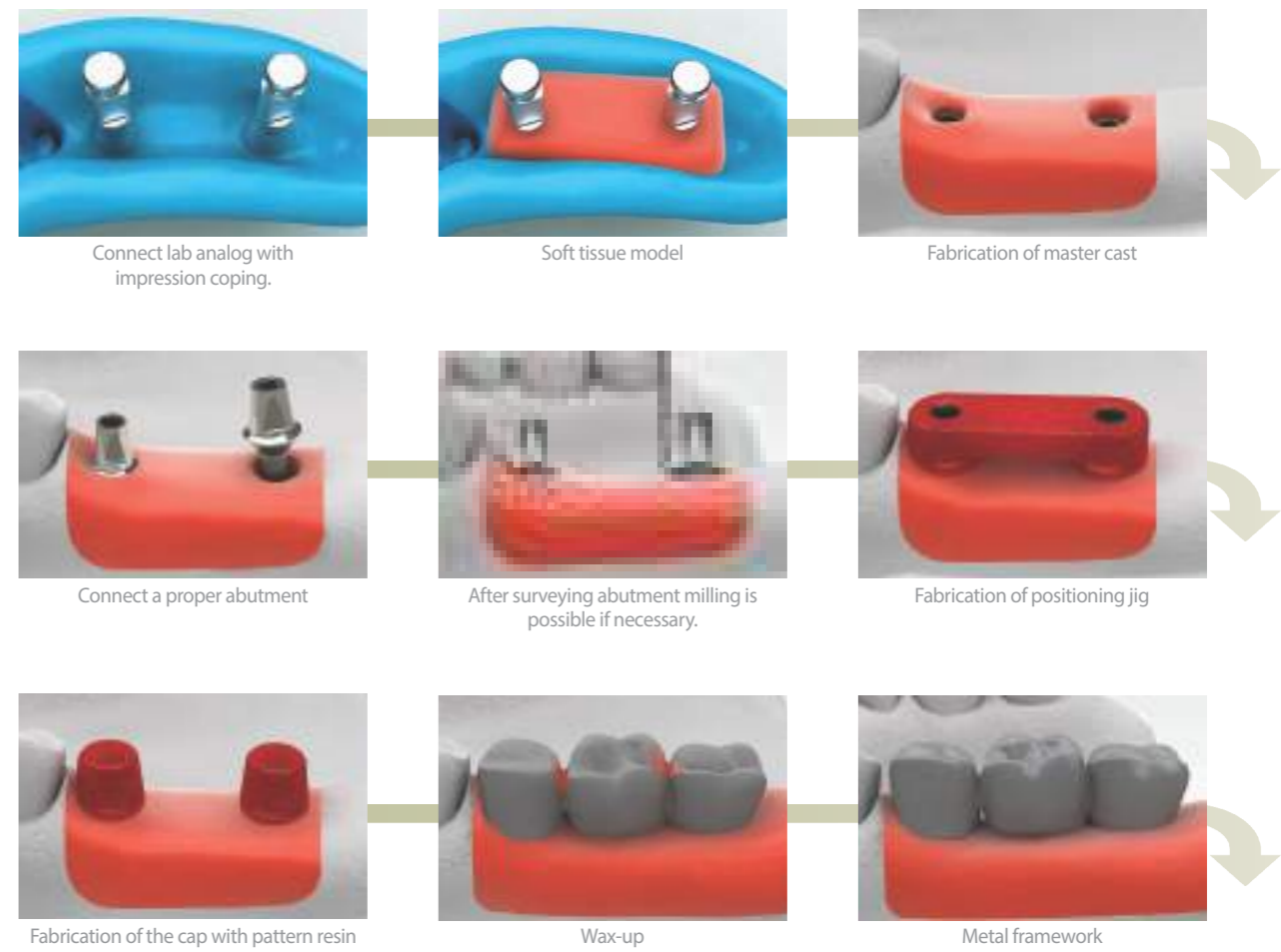

Fixture Level [Pick-up Type]_Dual Abutment

[Multiple Units]

Chairside



Final prosthesis



Use positioning jig to transfer the abutment in model to oral cavity then tighten it to 25~30N-cm. Retighten after 15 minutes.



Insertion of the final prosthesis and occlusal adjustment

* In the process of seating the prosthesis, the prosthesis can be rebounded by gingival tissue. In this case it is advised to apply occlusal load on the prosthesis for 10~15 minutes.

SCRP- Labside



Formation of access hole with long transfer coping screw



Wax-up



Metal framework

SCRP- Chairside



Final prosthesis



Use positioning jig to transfer the abutment in model to oral cavity then tighten it to 25~30N-cm. Retighten after 15 minutes.



Insertion of final prosthesis and adjustment of occlusion

* In the process of seating the prosthesis, the prosthesis can be rebounded by gingival tissue. In this case it is advised to apply occlusal load on the prosthesis for 10~15 minutes.

Fixture Level [Transfer Type]_Dual Abutment

[Multiple Units]

Clinical Procedure



Chairside



Second stage surgery (Uncovering)



Soft tissue formed around Healing Abutment

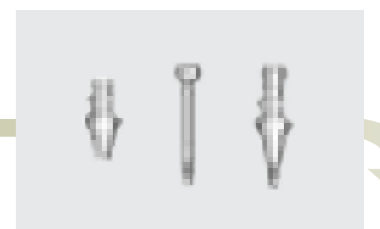

Transfer type impression coping



Seating the impression coping which has the same diameter as Healing Abutment



Impression of fixture level (No x-ray necessary for confirmation)



Injection of impression material

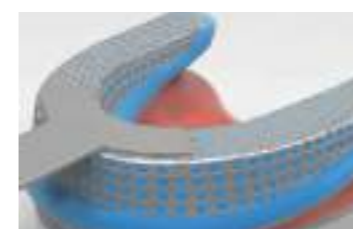

Impression taking



Inner surface of the impression

Fixture Level [Transfer Type]_Dual Abutment

[Multiple Units]

Clinical Procedure



LabSide

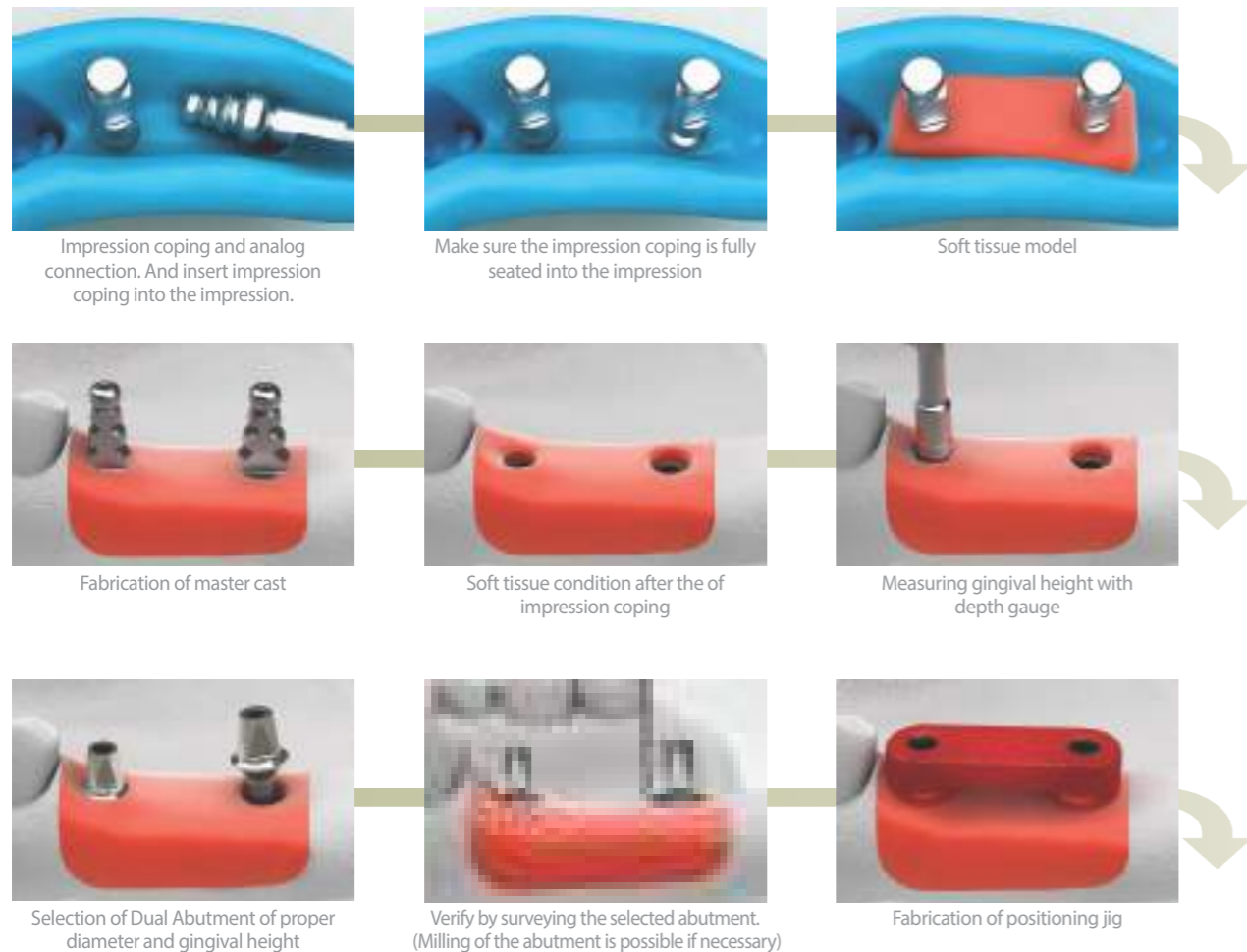

Fixture Level [Transfer Type]_Dual Abutment

[Multiple Units]



Chairside



SCRP- Labside



SCRP- Chairside



* In the process of seating the prosthesis, the prosthesis can be rebounded by gingival tissue. In this case it is advised to apply occlusal load on the prosthesis for 10~15 minutes.

Fixture Level [Transfer Type]_Milling Abutment

[Single Unit]

Clinical Procedure



Chairside

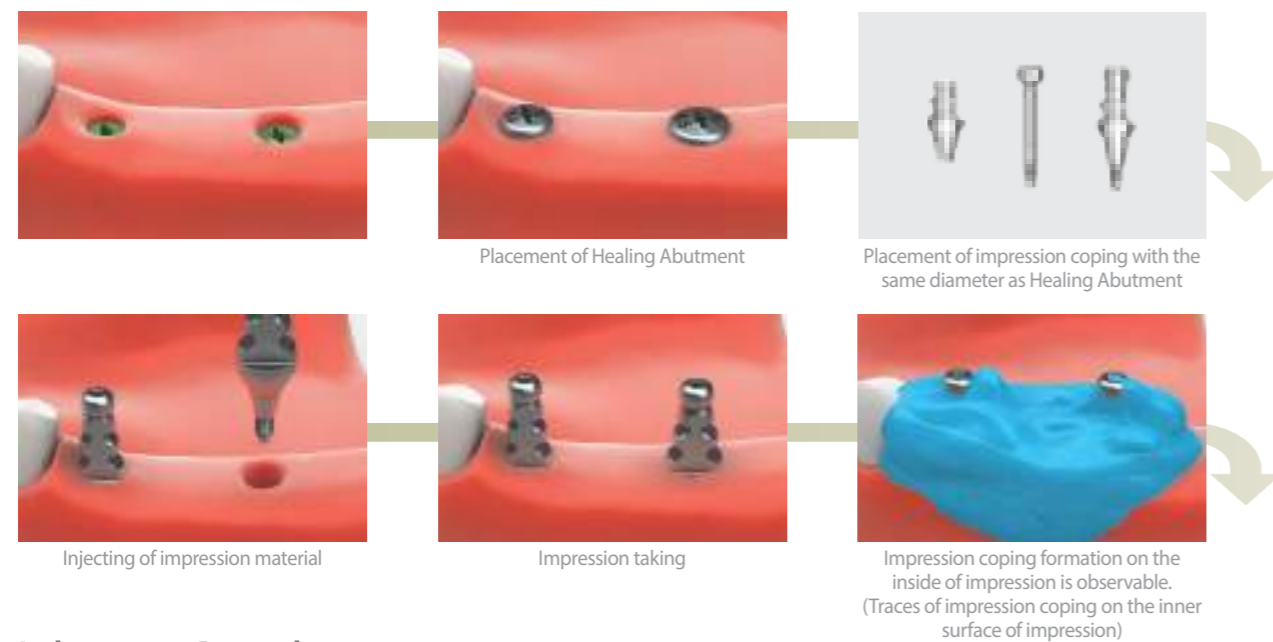

Laboratory Procedure

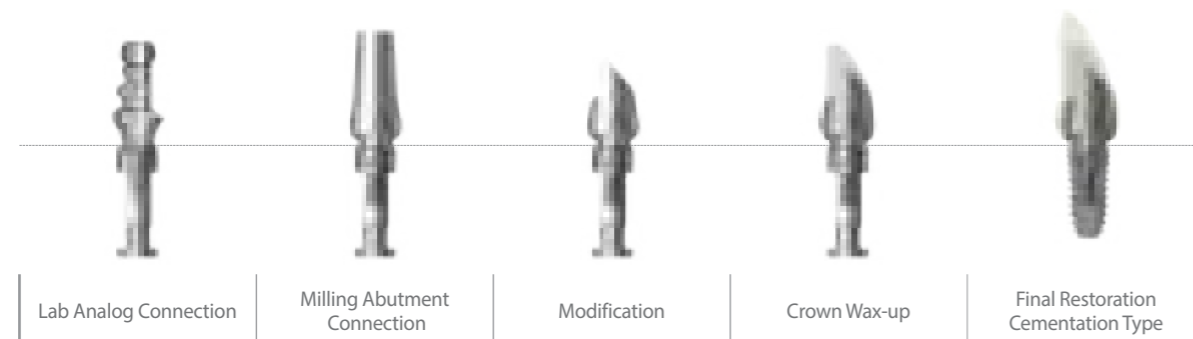

Fixture Level [Transfer Type]_Milling Abutment

[Single Unit]

Labside

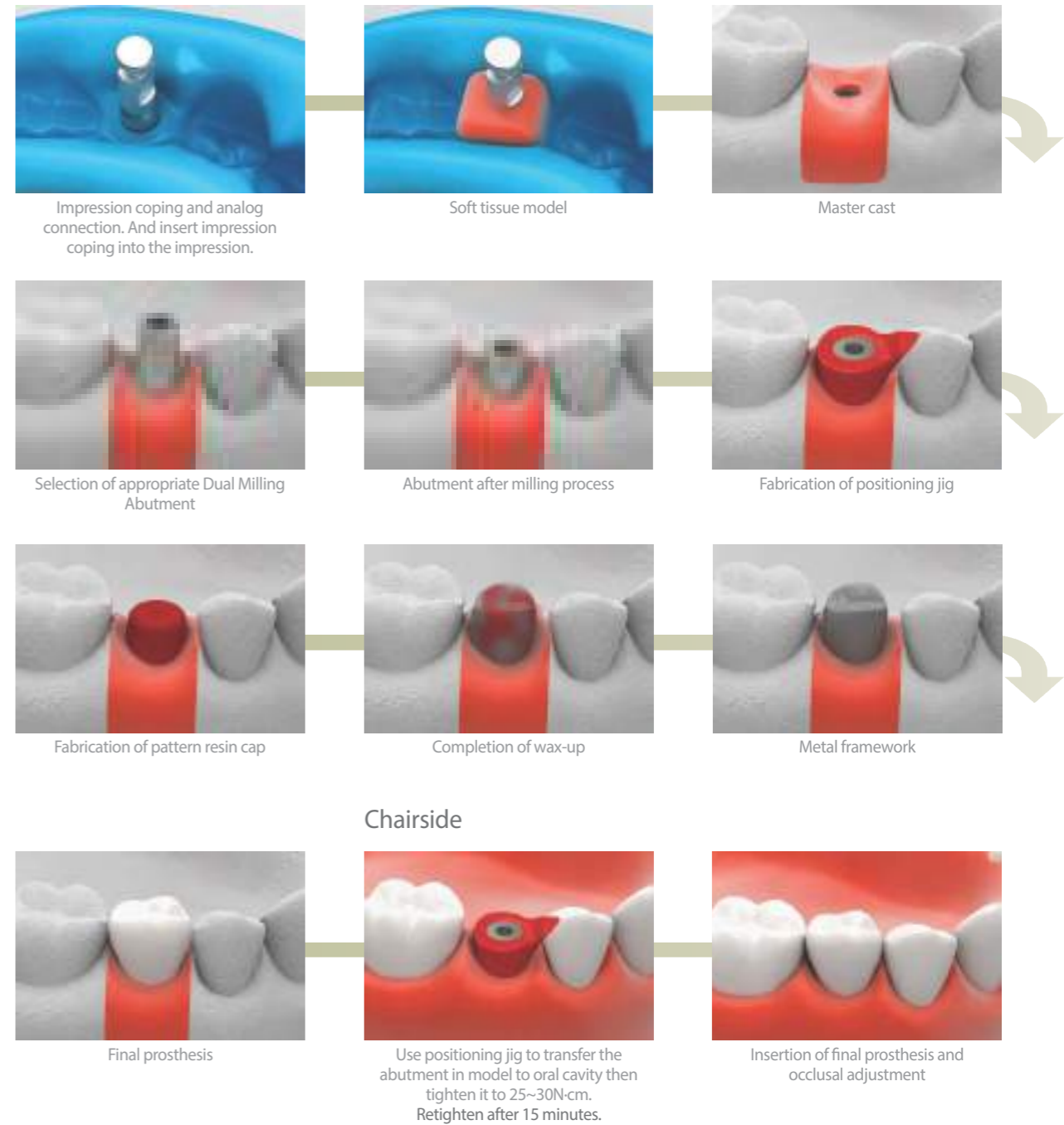

Chairside

* In the process of seating the prosthesis, the prosthesis can be rebounded by gingival tissue. In this case it is advised to apply occlusal load on the prosthesis for 10~15 minutes.

Fixture Level [Pick-up Type]_Angled Abutment

[Single Unit]

Clinical Procedure



Chairside

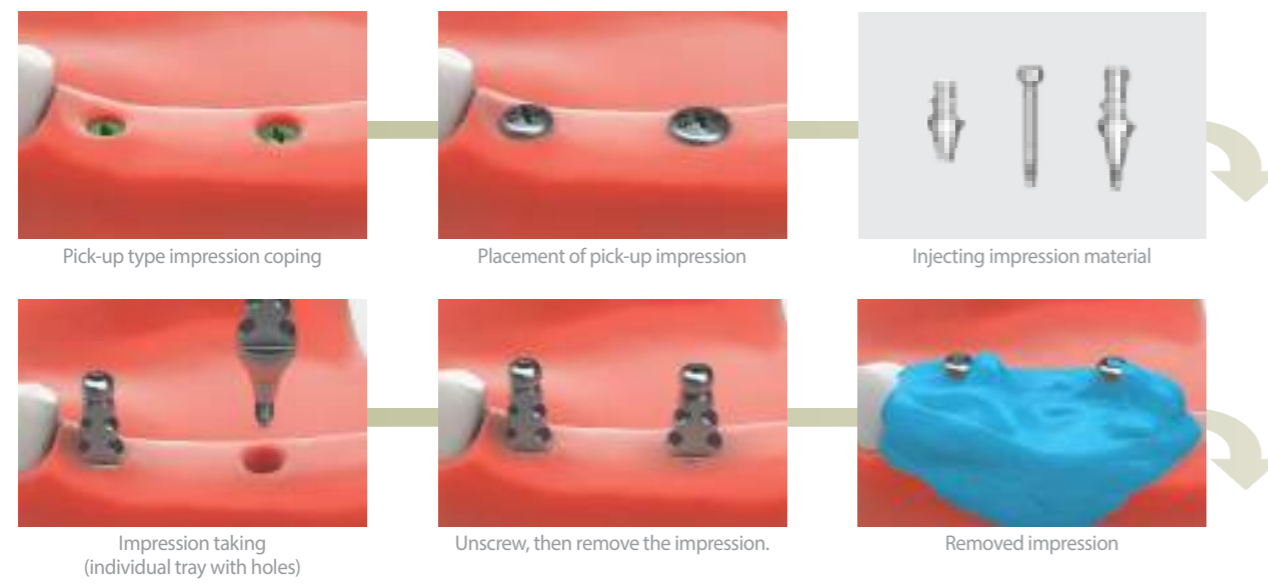

Laboratory Procedure

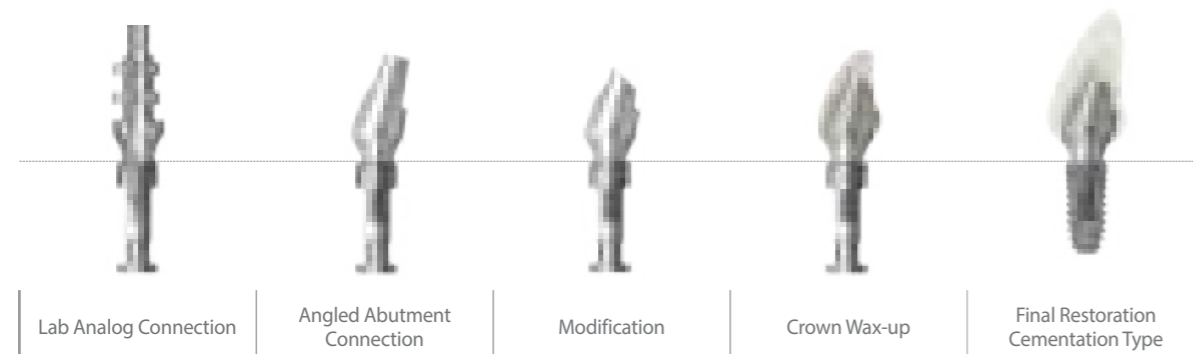

Fixture Level [Pick-up Type]_Angled Abutment

[Single Unit]

Labside

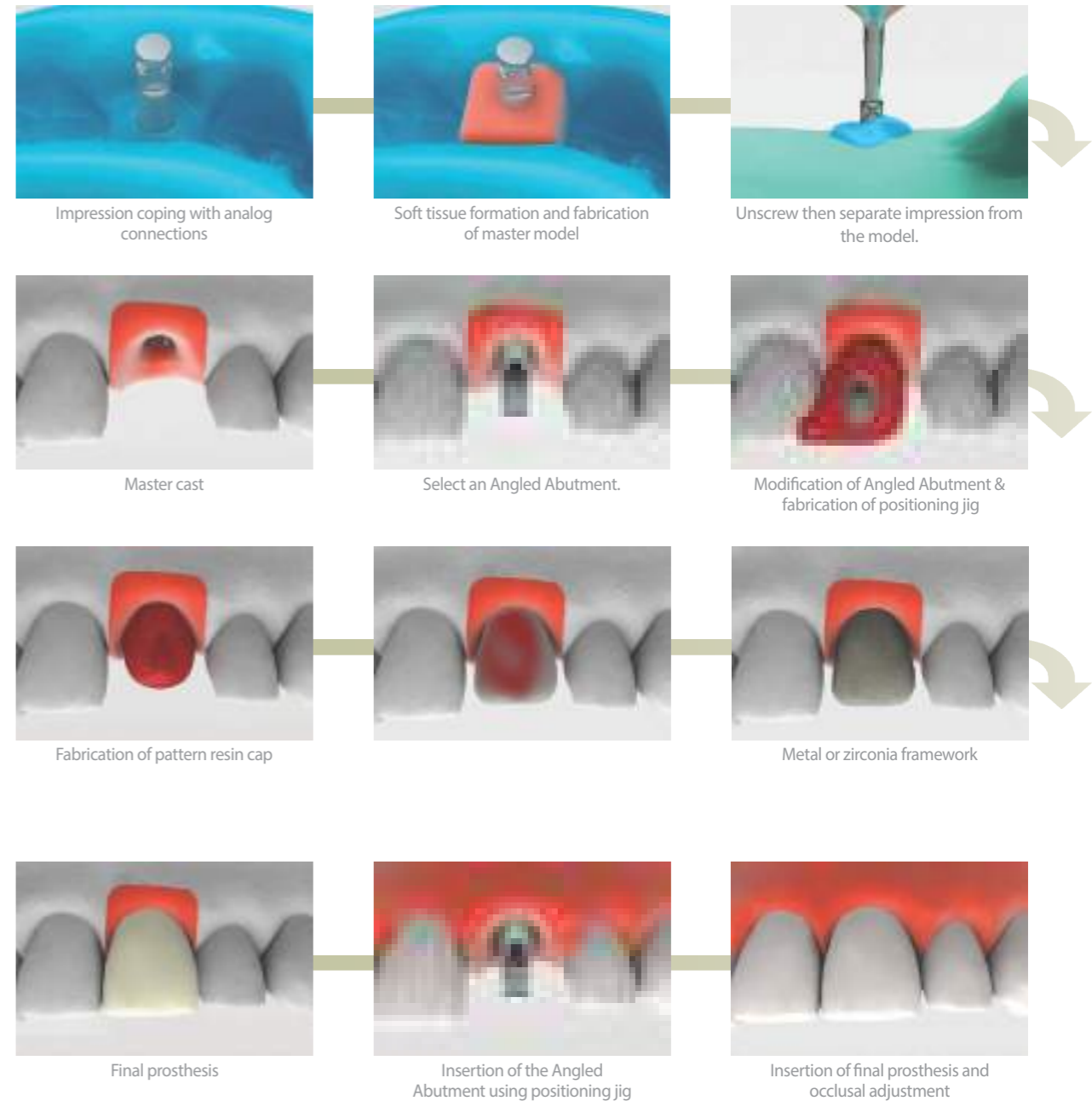

Fixture Level_Direct-Casting Abutment

[Single Unit]

Laboratory Procedure

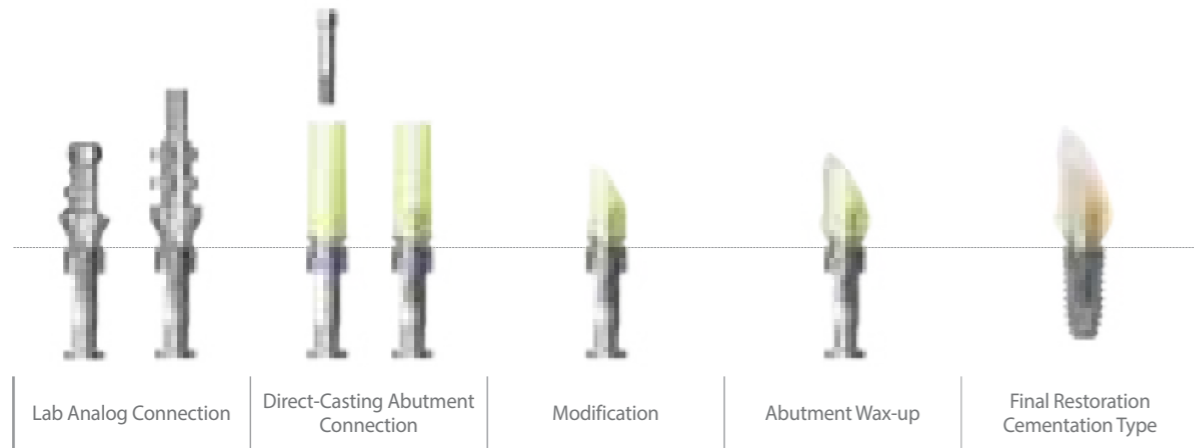

LabSide

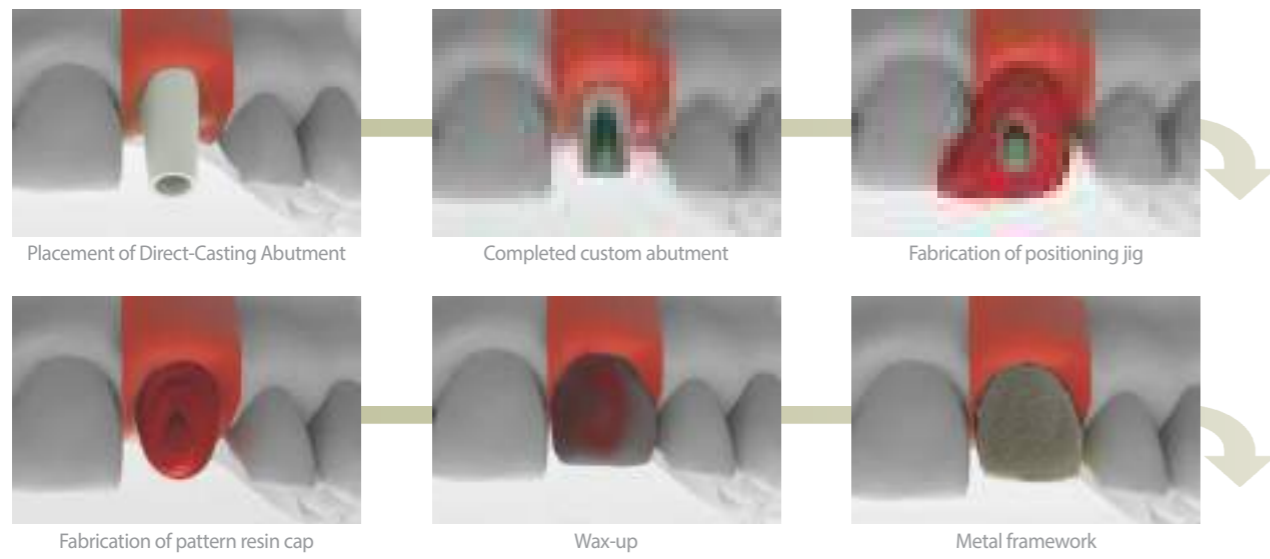

Chairside

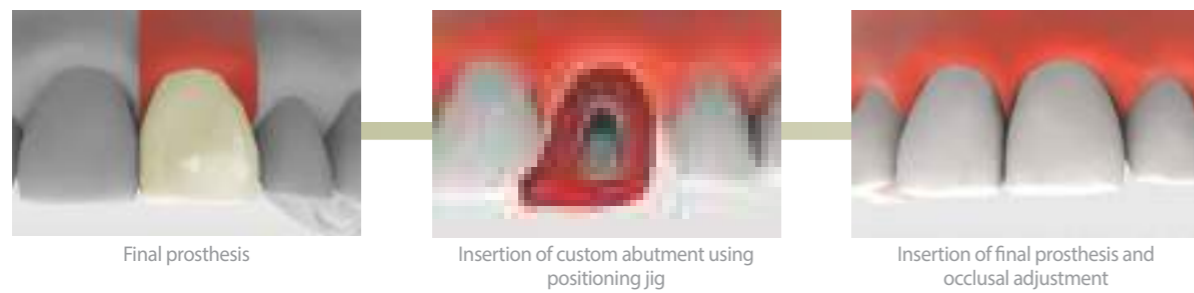

Fixture Level_Metal-Casting Abutment

[Single Unit]

Laboratory Procedure

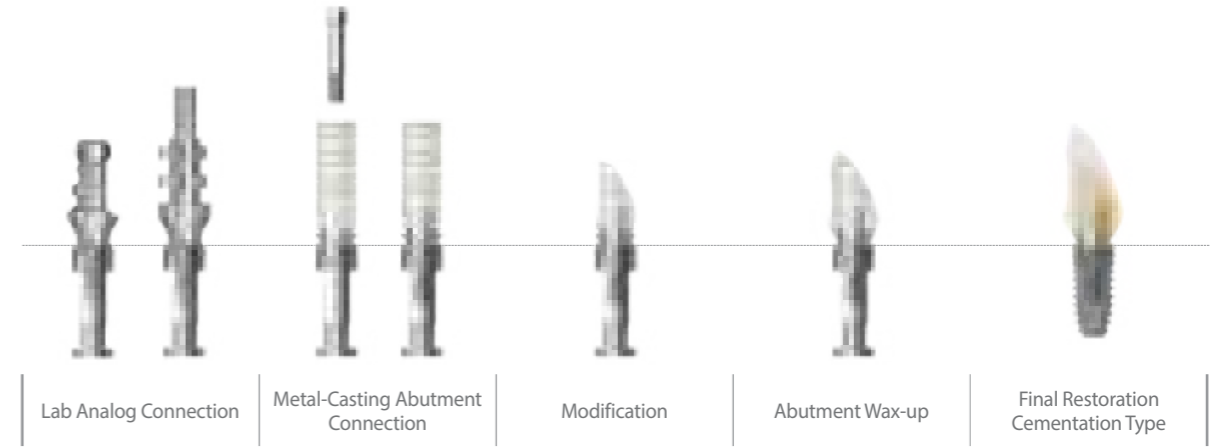

LabSide

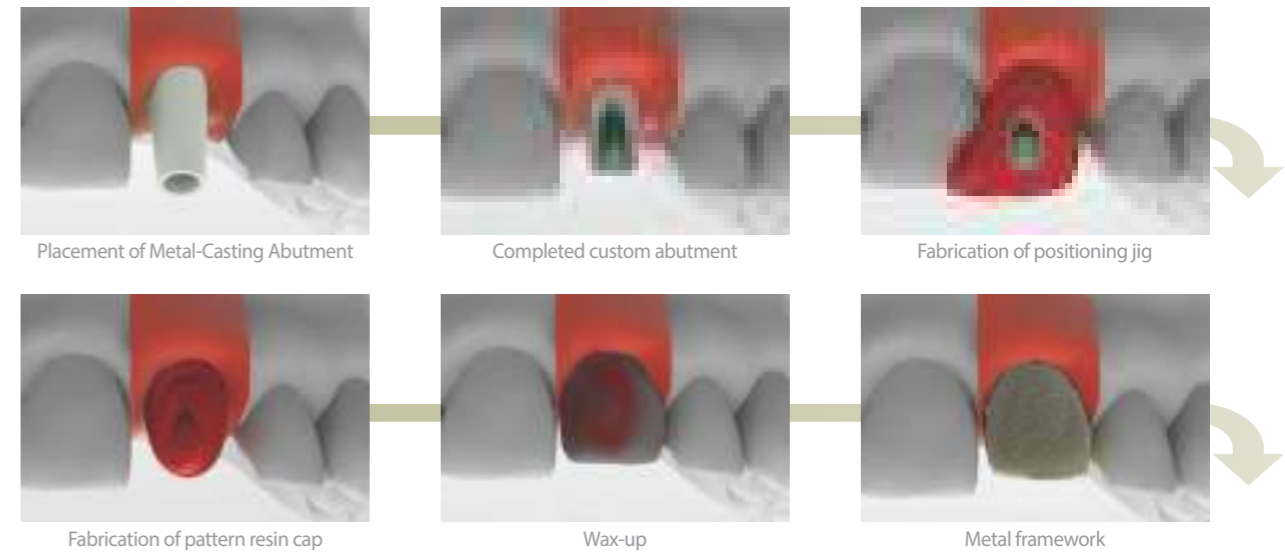

Chairside



Fixture Level [Pick-up Type]_Temporary Abutment

[Single Unit]



<Using Ti Abutment>



Considering the opposing teeth before seating the Temporary Abutment, trim off the abutment as needed and complete the Temporary Abutment prosthesis with direct resin.

<Using Plastic Abutment>



Prosthetic Procedure 3

Impression Technique and Restoration Selection

Screw Abutment

Abutment Level Impression

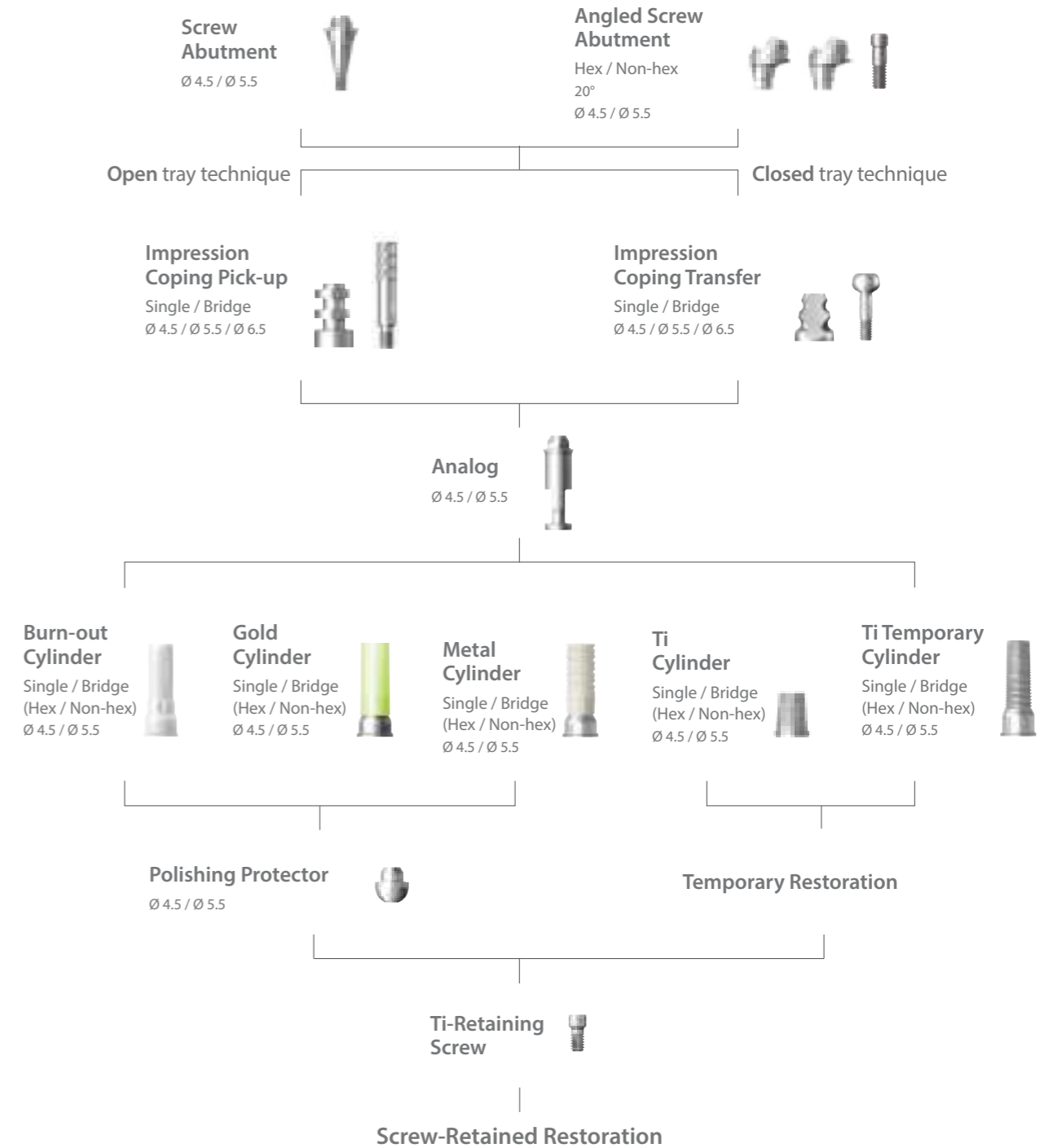

Abutment Level [Transfer Type]_Screw Abutment

[Multiple Units]

Clinical Procedure

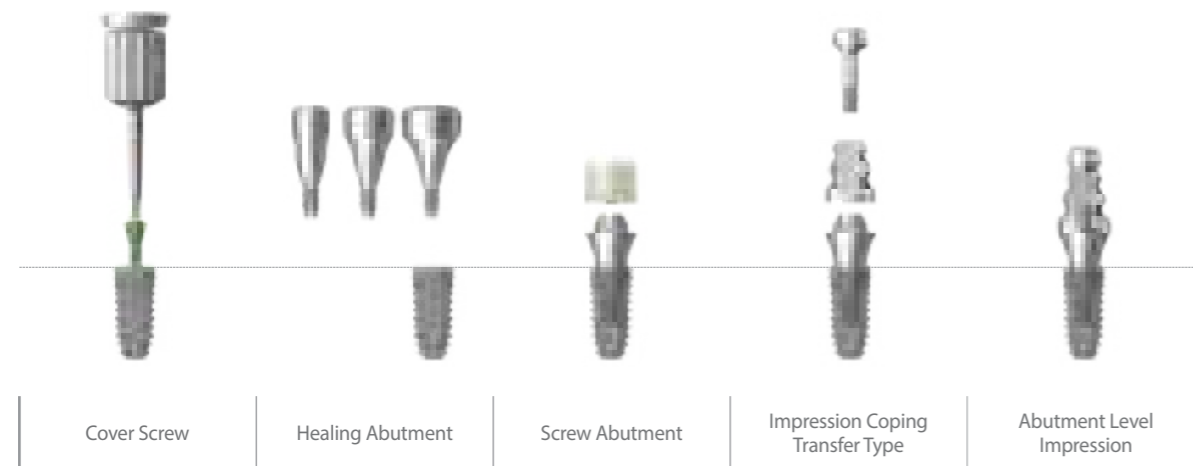

LabSide

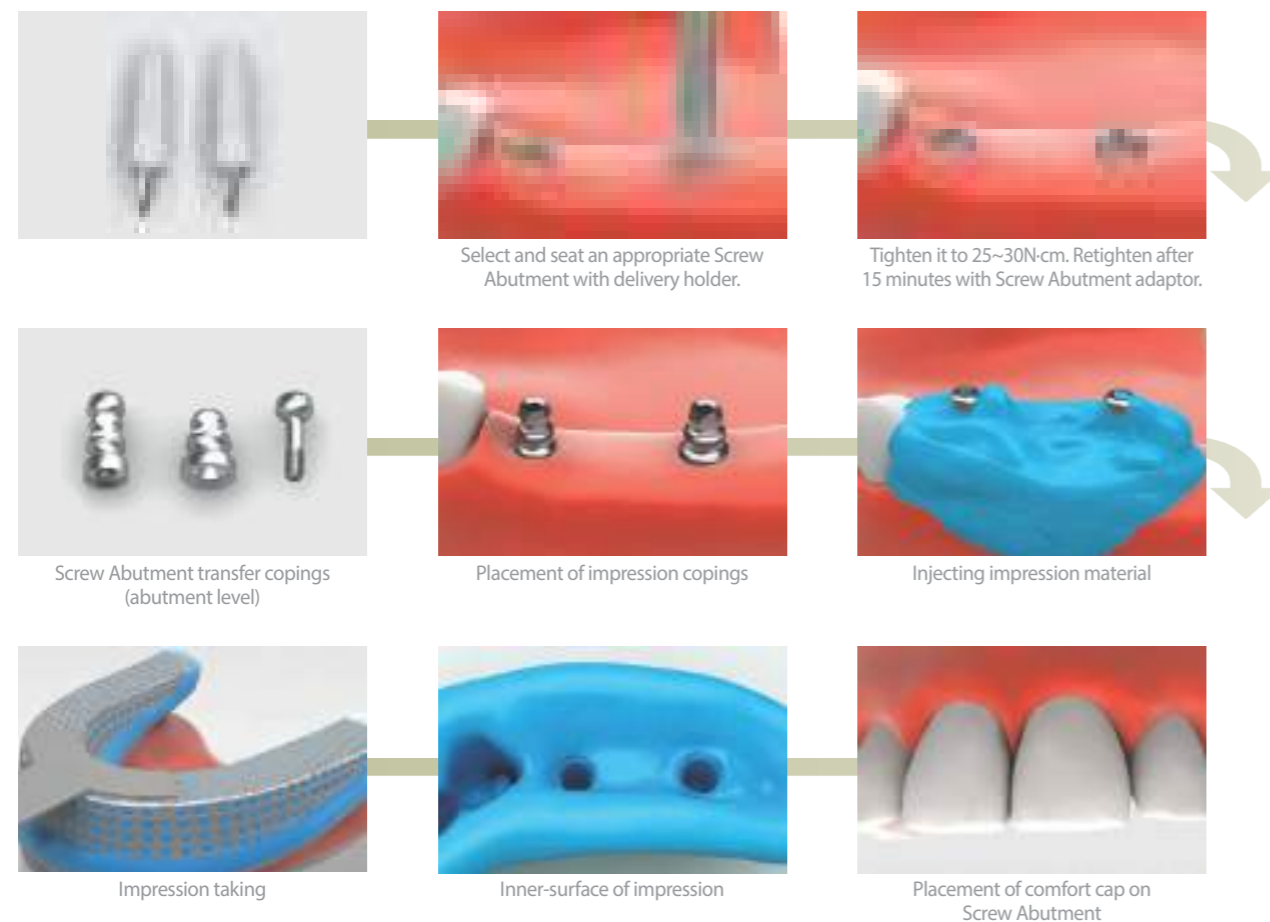

Abutment Level [Transfer Type]_Screw Abutment

[Multiple Units]

Laboratory Procedure

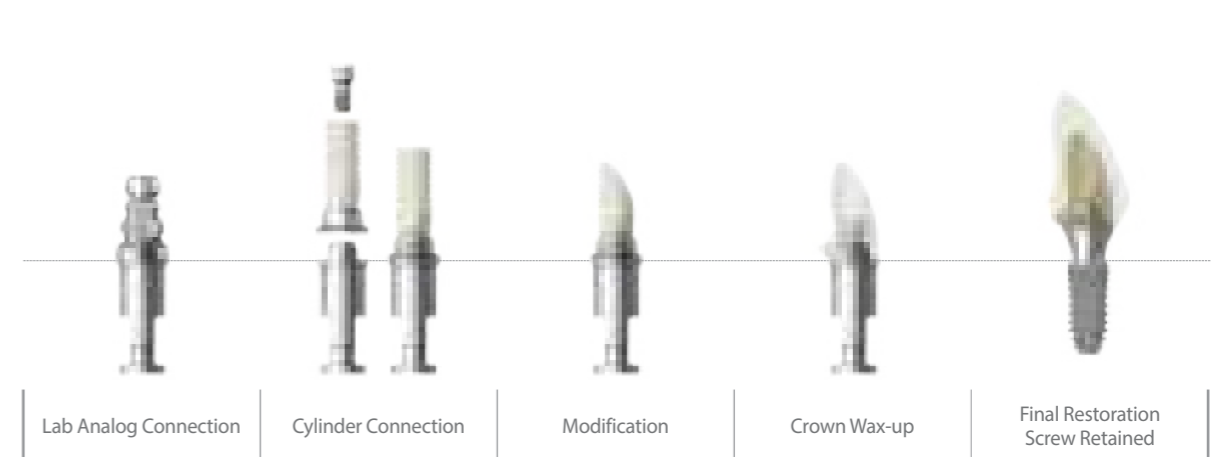

LabSide

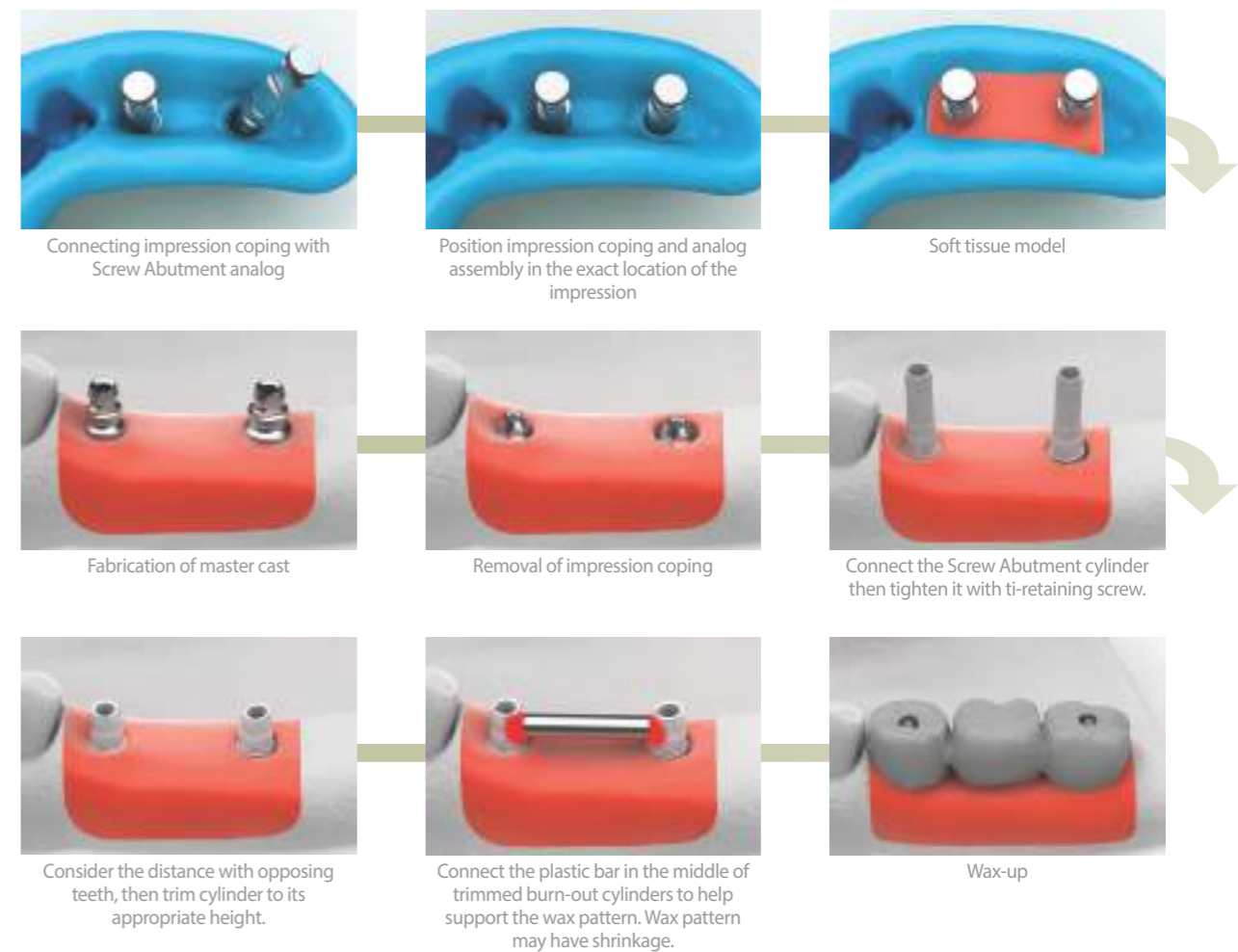

Abutment Level [Transfer Type]_Screw Abutment

[Multiple Units]

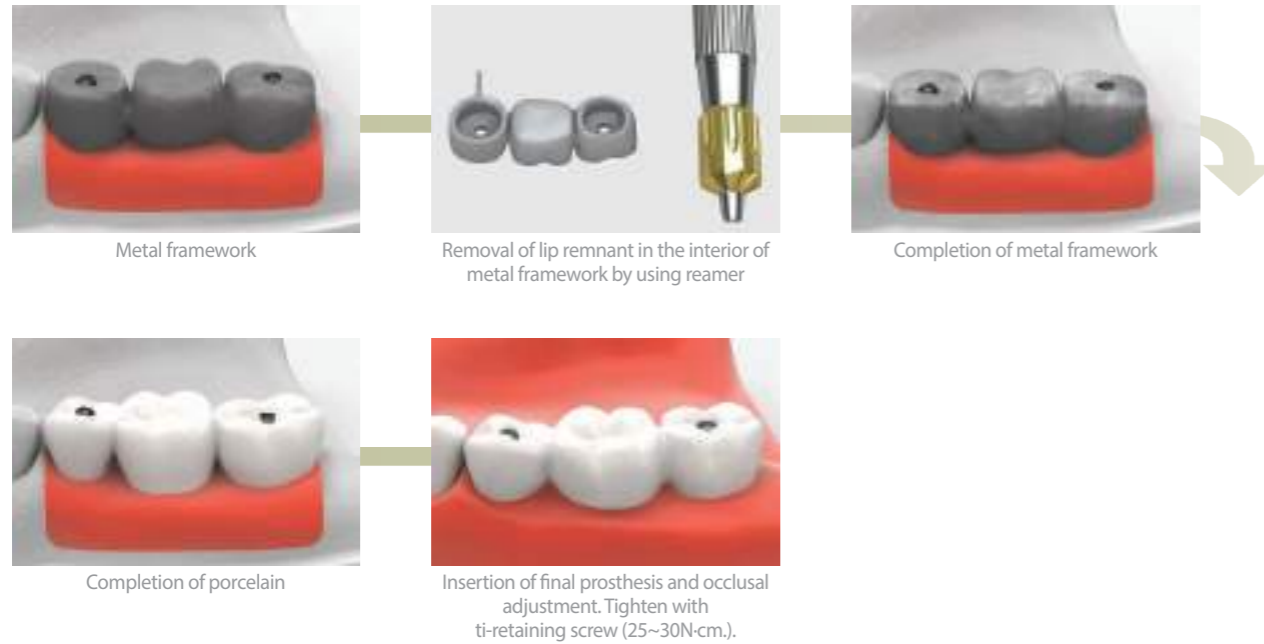

Cementation Repair Method (SCRIP)

[Screw & Cement Retained Prosthesis]

In Light of Implant Prosthesis:

- A screw type restoration helps to simplify prosthesis repair, including insertion and removal of the prosthesis if necessary.
- Cement type restoration tend to have a stable occlusion and may enhance the adaptability. However the weak point is that it cannot be removed after permanent cementation.
- A Dual Abutment can be cemented or screw retained.
- Combi Abutments are cement retained and no occlusal hole is necessary.

In Case of Screw Loosening or when Prosthesis Repair is Needed

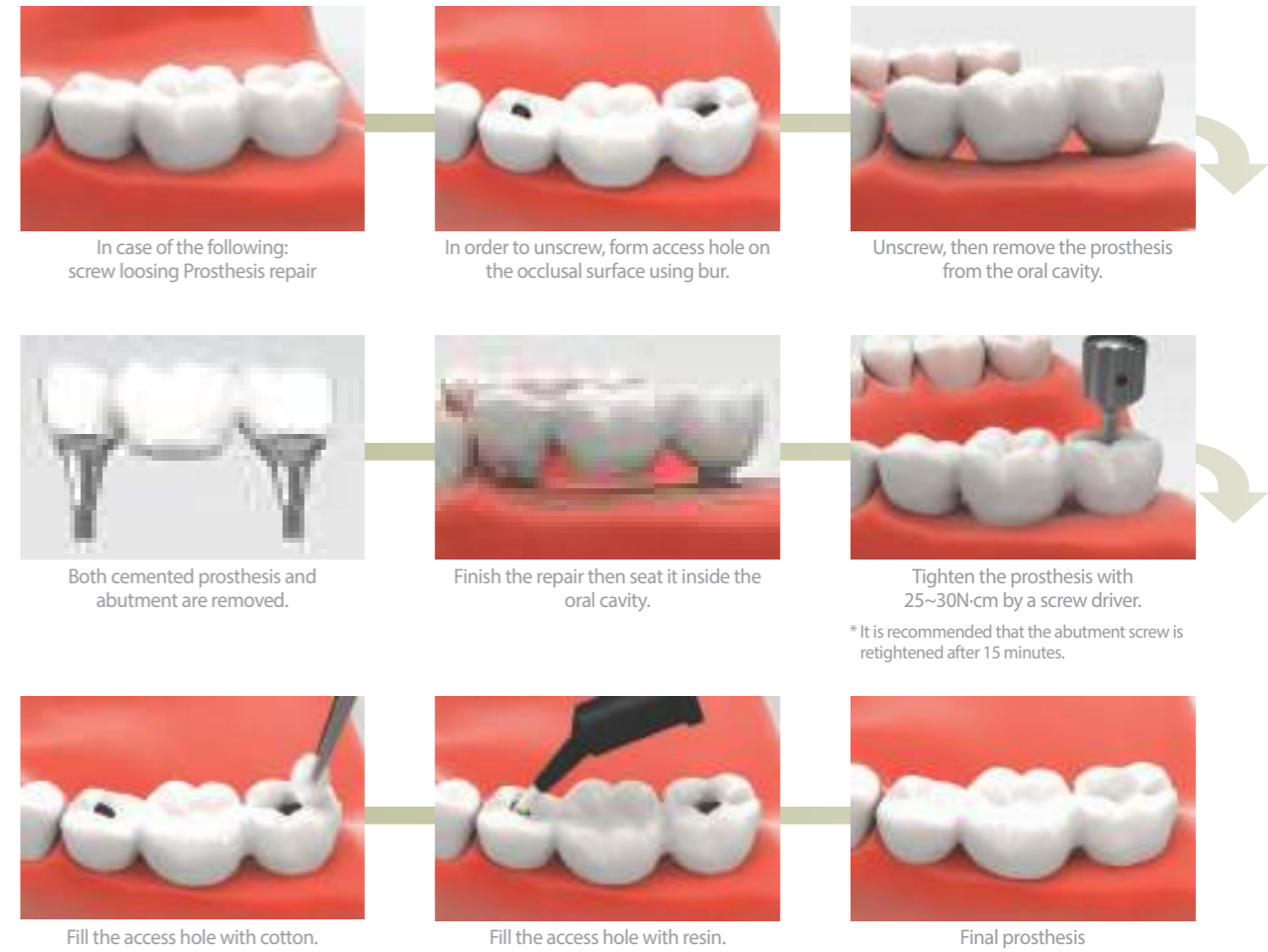

Cementation Repair Method (SCRP)

[Screw & Cement Retained Prosthesis]

Prosthesis Separation from Abutment due to Cement Loss

Remove the screw completely with screw driver and remove prosthesis from the patient's mouth.

Apply cement to the prosthesis.

Place it back into the patient's mouth.

After the cement setting, unscrew and remove the excessive cement.

Finish the repair and seat it inside the patient's mouth.

Tighten the prosthesis with 25~30N-cm with a screw driver.

Adding to the Interproximal Contact Surface due to Prosthesis Loosening

Prosthesis loosening due to contact loosening

Form access hole using bur

Unscrew, then remove the cemented prosthesis with abutment in the oral cavity.

Contact adding with resin on the prepared under space.

Insert the prosthesis in the oral cavity and screw it in. Afterwards, perform light curing, then polish the contact area.

* It is recommended that the abutment screw is retightened after 15 minutes.

Position the prosthesis in the mouth and tighten the screw with 25~30N-cm, then fill up the access hole.

Prosthetic Procedure 4

Impression Technique and Restoration Type

Overdenture Procedure

Positioner / Mini Ball / Magnetic Attachment

<p>Positioner Abutment Ø 3.5</p>	<p>Mini Ball Abutment Ø 3.5</p>	<p>Magnetic Implant Keeper Dome type / Flat type Ø 4.5 / Ø 5.5</p>
Abutment Level Impression		
<p>Positioner Impression Coping Ø 4.5</p>	<p>Mini Ball Impression Coping Ø 3.5</p>	
<p>Positioner Analog Ø 3.5</p>	<p>Mini Ball Analog Ø 3.5</p>	
<p>Block Out Spacer Ø 6.5</p>	<p>Socket Spacer Ø 4.05 / Ø 4.85</p>	
<p>Positioner Socket Metal / Plastic</p>	<p>Mini Ball Female Socket / O-ring Ø 4.05 / Ø 4.85</p>	<p>Magnetic Assay Dome type / Flat type Ø 4.5 / Ø 5.5</p>
Positioner Attachment for Overdenture	Mini Ball and Socket Attachment for Overdenture	Magnetic Attachment for Overdenture

Positioner

Chairside

Connect the Positioner Abutment onto the fixture.

Affix the impression coping on the Positioner Abutment.

Take Impression for the production of individual tray.

Produce the individual tray for denture impression.

After connecting the Positioner Abutment and the impression coping together, apply the impression material.

Take the final impression with the prepared individual tray.

After the impression material is set, discard the individual tray.

Image of the set final impression (with impression coping)

Labside

Positioner Analog

Insert the Positioner Analog into the embedded impression coping.

Create the master model.

"Block out" procedure to achieve the space required for the metal socket.

Fabrication of denture with conventional method

Positioner

Case 1

Chairside

Secure spaces for the female sockets.

Place the "block out spacer" on the Positioner Abutment in the patient's mouth.

Connect the metal socket onto the Positioner Abutment.

Apply a small amount of resin into the space created for the metal socket.

Position the denture in the mouth and wait until the resin is completely set.

Remove the white plastic socket (100gf) using the positioner tool and assemble with the regular plastic socket giving the desired retention force (300, 500 or 1000gf).

Secure spaces for the female sockets.

Place the "block out spacer" on the Positioner Abutment in the patient's mouth.

Connect the metal socket onto the Positioner Abutment.

Positioner

Case 1

Chairside



Create holes for the placement of the metal sockets.



Place the "block out spacer" on the Positioner Abutment in the intraoral.



Connect the metal socket onto the Positioner Abutment.



Examine the interference between inner surface of the holes and the female sockets.



Apply the resin into the holes and wait until it is completely set.



Remove the white plastic socket (100gf) using the Positioner tool and assemble with the regular plastic socket giving the desired retention force (300, 500 or 1000gf).



Apply additional resin around the metal socket where there is a shortage of resin.



Apply resin around the metal socket.



After polishing, the overdenture is completed.

Mini Ball Attachment

Case 1

Chairside



Secure spaces for the female sockets.



Connect the female sockets to the Mini Ball Abutments in the intra-oral.



Apply small amount of the resin into the secured area.



Position the denture in the oral cavity and wait until the resin is completely set.



Female sockets are placed in the denture.



After polishing, the overdenture is completed.

Case 2

Chairside



Create holes for placement of female sockets.



Connect the female sockets to the Mini Ball Abutments in the intra-oral.



Examine the interference between inner surface of the holes and the female sockets.



Apply the resin into the holes and wait until it is completely set.



Female sockets are placed in the denture.



Apply resin around the female sockets.



After polishing, the overdenture is completed.

Magnetic Attachment

Chairside



After Healing Abutment removal



Connect implant keeper with fixture and tighten it with 25~30N-cm.



Implant keepers connected with the fixtures



Position the magnetic assay on the implant keeper.



Secure spaces for the magnetic assays.



Examine the interference between inner divot of the denture and the magnets.

Case 1



Apply resin on the divot of the denture's inner surface.



Position the denture into the mouth and wait until the resin is completely set.



Magnetic assays are placed in the denture.



Apply some of resin around the magnetic assays.



After the resin is completely set, remove excess. After polishing, the overdenture is completed.

Chairside

Magnetic Attachment

Case 2



Create holes for the placement of the magnets.

Chairside



Examine the interference between inner surface of the holes and the magnets.



Position the denture in the mouth and apply small amount of resin into the hole.



Wait until the resin is completely set.



After setting, remove denture from the mouth.



Add the resin around the magnets.



After polishing, the overdenture is completed.

DENTIUM LONG-TERM CLINICAL DATA

Dentium
For Dentists By Dentists

over **15** years
of Long
term
data

OVER A **DECADE** OF
COMMITMENT TO
THE **BEST PRODUCTS**
FOR DENTISTS AND
PATIENTS

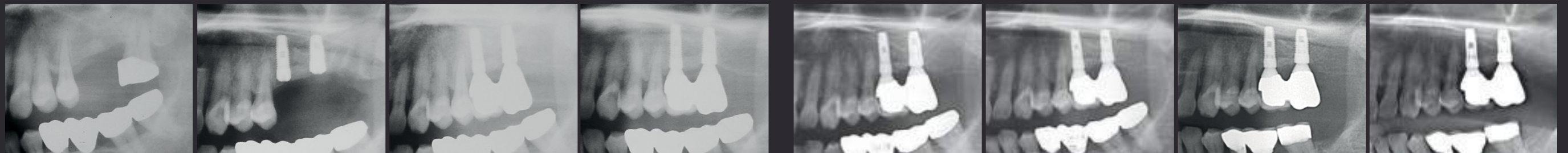

06. 20. 2002
Pre-op

07. 02. 2002
Post-op

11. 29. 2002
Final Prosthesis

06. 02. 2004
1 Years 2 months

11. 15. 2007
5 Years

07. 24. 2009
6 Years 8 months

05. 23. 2012
9 Years 6 months

11. 25. 2017
15 Years